

# ***Hustler FasTrak Super Duty CE Parts Manual***



**HUSTLER®**

•••••

*Excel Industries, Inc.*

••••

*P.O. Box 7000*

•••

*Hesston, Kansas*

•

*67062-2097*



---

# Table of Contents

<b>Section 1</b>	
General Information . . . . .	1-1
<b>Section 2</b>	
Frame CE . . . . .	2-2
Footrest . . . . .	2-4
Engine Guard . . . . .	2-6
<b>Section 3</b>	
Hydraulic System . . . . .	3-2
Steering . . . . .	3-4
Steering Sub-Assembly . . . . .	3-10
Brake . . . . .	3-12
<b>Section 4</b>	
Wheel and Tire . . . . .	4-2
Drive Wheel Breakdown . . . . .	4-4
<b>Section 5</b>	
Engine, 23 HP Kaw . . . . .	5-2
Fuel . . . . .	5-6
<b>Section 6</b>	
Battery . . . . .	6-2
Instrument Panel . . . . .	6-4
Electrical Schematic—601341 . . . . .	6-6
<b>Section 7</b>	
54" Deck Decals . . . . .	7-2
54" Deck Pulley Assembly . . . . .	7-4
54" Deck . . . . .	7-8
54" Deck Belt Routing and Tensioning . . . . .	7-10
Deck Lift . . . . .	7-12
Deck Mounting Hardware . . . . .	7-14
<b>Section 8</b>	
Seat . . . . .	8-2
ROPS . . . . .	8-4
Index . . . . .	i-1



# Section 1

## General Information

This Manual covers Hustler Fastrak Super Duty model **928382CE**.

---

## Frequently Ordered Parts

<b>PART NO.</b>	<b>DESCRIPTION</b>	<b>PART NO.</b>	<b>DESCRIPTION</b>
600979	Pump Drive Belt	068478	Fuel Filter Kawasaki
791335	Deck Belt 48"	772079	Engine Oil Filter Kawasaki
789388	Deck Belt 54"	600976	Oil Filter ZT 2800
782292	Deck Belt 60"	794685	F20.50"-L-F-CW Blade
785261	Main Air Filter Element Kaw	797696	F18.50"-L-F-CW Blade
785279	Air Filter Element Kaw	795757	F16.50"-L-F-CW Blade
602882	Panel Air Filter Honda	602883	Foam Outer Filter Honda
785634	Engine Oil Filter Honda		

---

## Service Literature

<b>PART NO.</b>	<b>DESCRIPTION</b>
799411CE	CE Owner's Manual
778423	Kawasaki Engine Manual

---

*Note:* When ordering parts, you must use the part number as shown for each part, not the index number. Always give the model and serial number to your parts and service representative.

*Note:* Items sold in bulk such as seals and hoses are sold by the foot.

---

## Using this manual

Illustrations used were current at the time of printing, but subsequent production changes may cause your machine to vary slightly in detail. Excel Industries, Inc. reserves the right to redesign and change the machine as deemed necessary, without notification. If a change has been made to your machine which is not reflected in this parts manual, see your Hustler dealer for current information and parts.

## Hardware Description Codes & Abbreviations

The following codes are used throughout this parts manual. Refer to this list when ordering parts

<b>ABBREVIATION</b>	<b>DESCRIPTION</b>	<b>ABBREVIATION</b>	<b>DESCRIPTION</b>
CB	Carriage Bolt	MB	Machine Bushing
CE	Clevis Pin	MS	Machine Screw
CP	Cotter Pin	NT	Nut
CN	Clip Nut	SC	Self Tapping Cap Screw
CS	Cap Screw	SH	Socket Head
CW	Cup Washer	SB	Shoulder Bolt
FDRW	Fender Washer	SS	Set Screw

<b>ABBREVIATION</b>	<b>DESCRIPTION</b>	<b>ABBREVIATION</b>	<b>DESCRIPTION</b>
FW	Flat Washer	OD	Outside Diameter
HX	Hex Head	ID	Inside Diameter
LW	Lock Washer		

### **Standard Torques**

The following chart lists the standard torque values for the threaded fasteners found in this manual. Torque all cap screws, nuts and set screws to these values unless a different torque is shown in the Notes section next to the fastener.

<b>SIZE</b>	<b>FT-LBS</b>	<b>NM</b>	<b>SIZE</b>	<b>FT-LBS</b>	<b>NM</b>
.250	8.2	11.1	M3	1	1.3
.312	17	23	M4	2.2	3
.375	30	40	M5	4.5	6.1
.438	48	65	M6	7.7	10.4
.500	73	99	M8	18.5	25
.562	105	143	M10	37	50
.625	145	200	M12	64	87
.750	260	350	M14	80	108.5
.875	420	565	M16	160	215
1.00	625	850	M20	320	435
			M24	555	750

**NOTE:**

**Loctite® 592 to be used on all pipe threads.  
Lubricate all grease zerks.**

---

## Section 2

Frame CE .....	2-2
Footrest .....	2-4
Engine Guard.....	2-6

# **Frame CE**

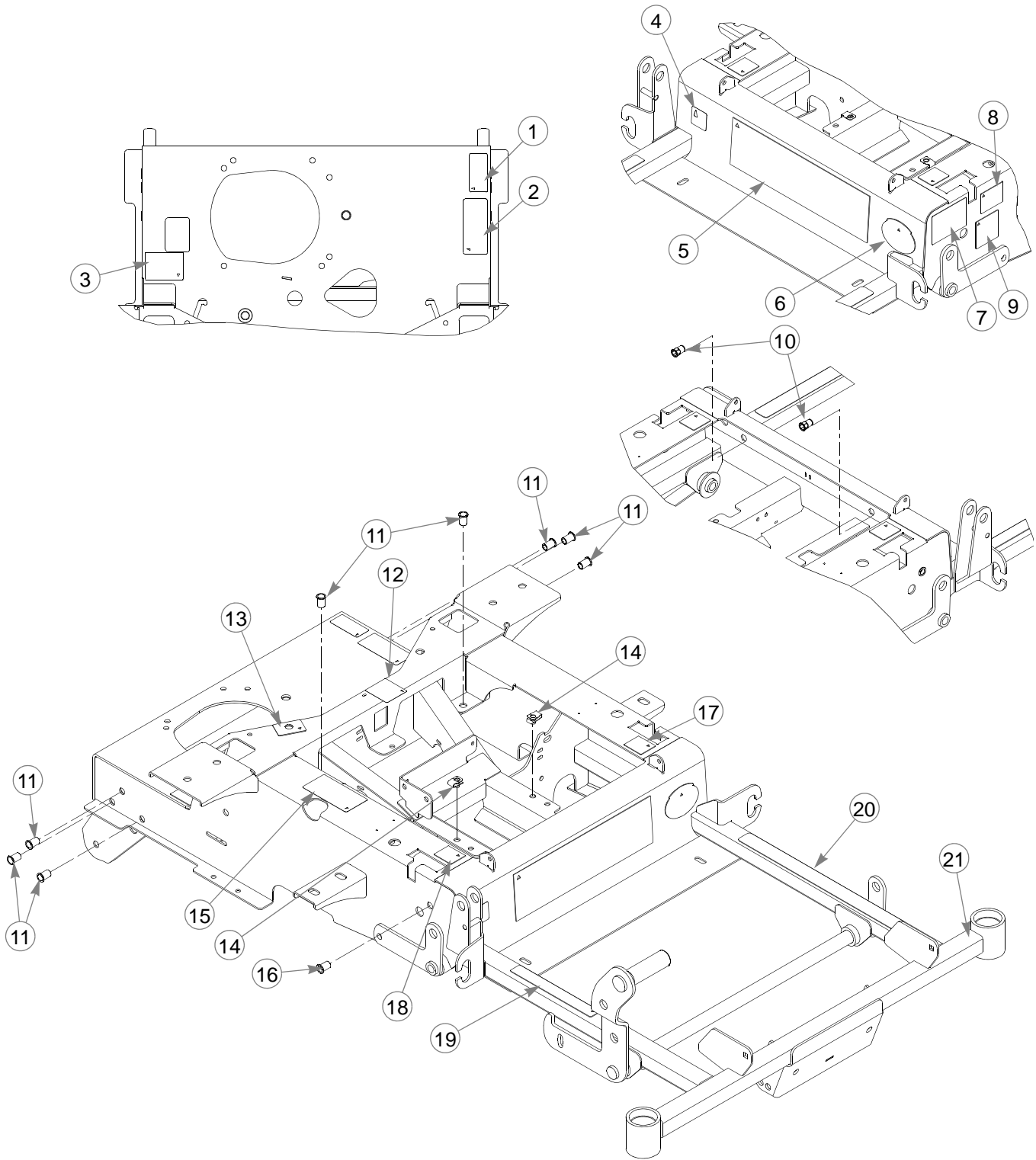



---

# **Frame CE**

INDEX NO.	PART NO.	QTY.	DESCRIPTION
1	602041	1	HOT DECAL
2	601967	1	ENGINE COMPARTMENT DECAL
3	601099	1	TOW VALVE DECAL
4	727172	1	MADE IN USA DECAL
5	601421	1	FASTRAK SUPER DUTY DECAL
6	782573	1	FIRST ZERO TURN DECAL
7	N/A	1	TURF PRODUCT SERIAL NO PLATE
8	776310	1	CE MARK DECAL
9	789776CE	1	CE 105 DBA LIMIT DECAL
10	600994	2	RIVET NUT, 3/8-16 THREAD
11	808493	8	RIVET NUT, 3/8-16 THREAD
12	602562	1	NO SERVICE DECAL
13	791848	1	FUEL INDICATOR DECAL
14	601069	2	CN .312-18 X .200 MAX THK
15	600899	1	PUMP BELT WARNING DECAL
16	808485	1	RIVET NUT, 5/16-18 THREAD
17	785139	1	STEERING LS DECAL
18	785220	1	STEERING RS DECAL
19	785154CE	1	DECK HEIGHT INDICATOR DECAL
20	601981	1	SAFE OPERATION DECAL
21	548743CE	1	FRAME (USED ON 928382CE)

---

## **NOTES:**

1. Service part frames include decals.

# Footrest

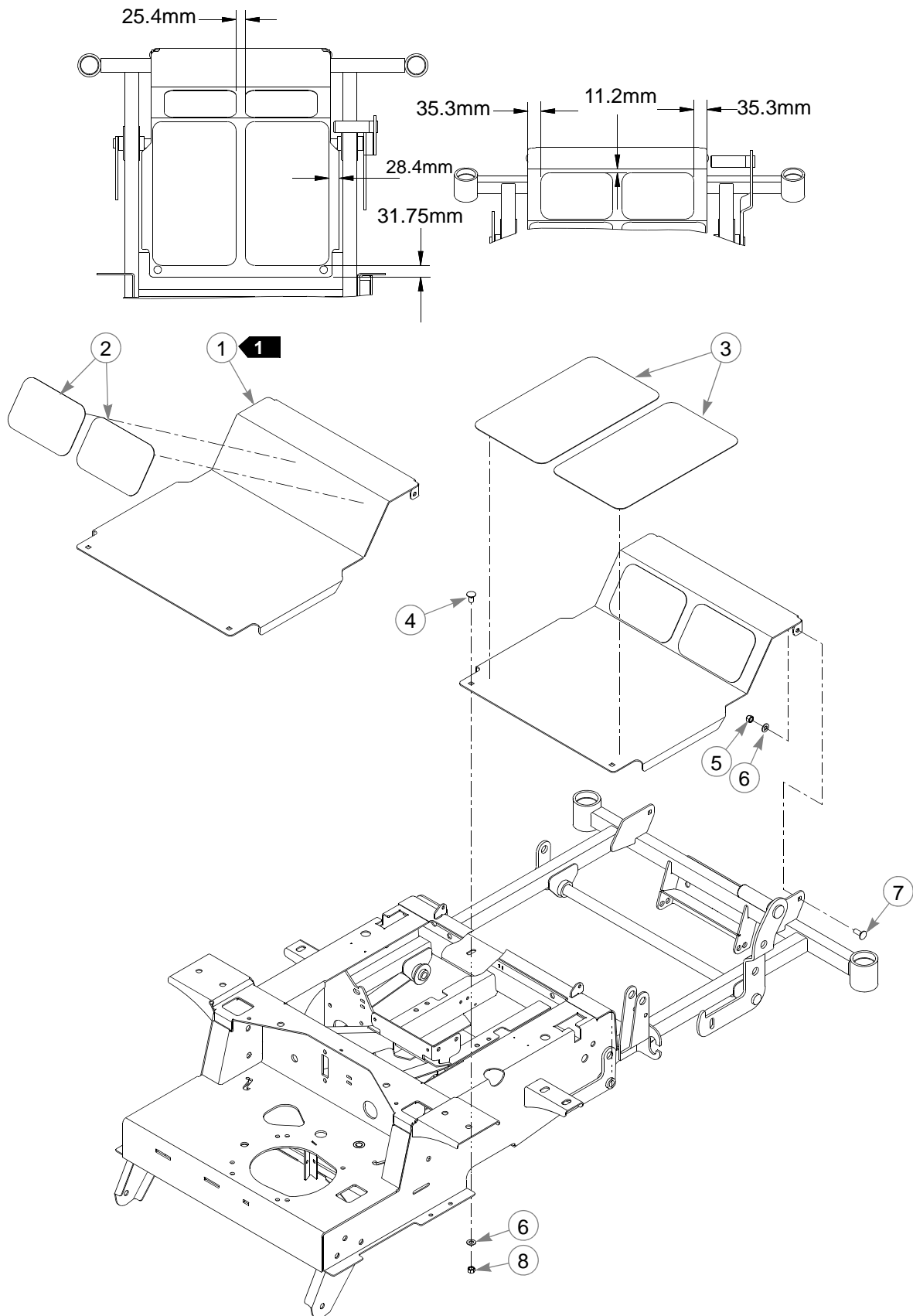

---

# **Footrest**

INDEX NO.	PART NO.	QTY	DESCRIPTION
1	548768	1	FLOOR PAN
2	785485	2	STEP TREAD, UPPER
3	785493	2	STEP TREAD, LOWER
4	011320	2	CB .375-16 X .750 STD ZN
5	086660	2	NT .375-16 HXZY NL
6	767954	4	FW .406 X .812 X .060 SAE
7	025395	2	CB .375-16 X 1.000 STD CD
8	054502	2	NT .375-16 HX G5 ZN

---

## **NOTES:**

1. Item 1 (Floor Pan) includes Items 2 & 3(Step Treads).

# Engine Guard

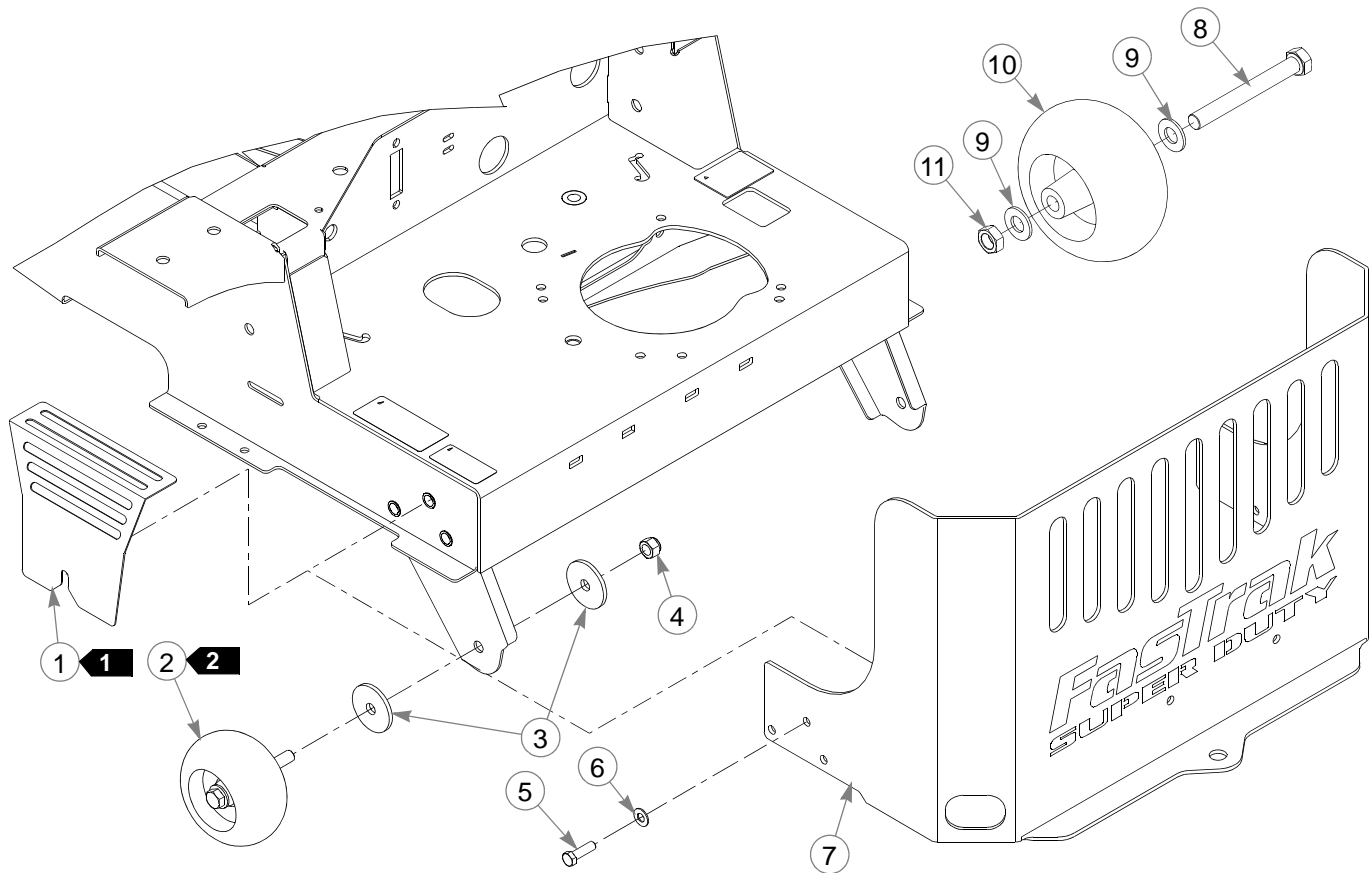

INDEX NO.	PART NO.	QTY.	DESCRIPTION
1	108541	1	HEAT SHIELD CE
2	788166	2	WHEEL ASSY, ANTI SCALP
3	344267	4	FW .510X 2.15X.187 SPL
4	781567	2	NT .500-13 HX G8 ZY NL
5	052860	6	CS .375-16X1.250 HX G5
6	767954	6	FW .406X .812 X.060 SAE
7	108847	1	ENGINE GUARD
8	781708	2	CS .500-13X4.250 HX G5
9	767962	4	FW .531X 1.063X.090 SAE
10	031997	2	ANTI-SCALP WHEEL
11	053199	2	NT .500-13 HX JAM ZNYC

## NOTES:

1. Install Item 1 (Heat Shield) between the engine guard and the frame.
2. Item 2 (Anti-scalp Wheel) includes (items 8–11).

---

## Section 3

Hydraulic System . . . . .	3-2
Steering . . . . .	3-5
Steering Sub-Assembly . . . . .	3-11
Brake . . . . .	3-13

# Hydraulic System

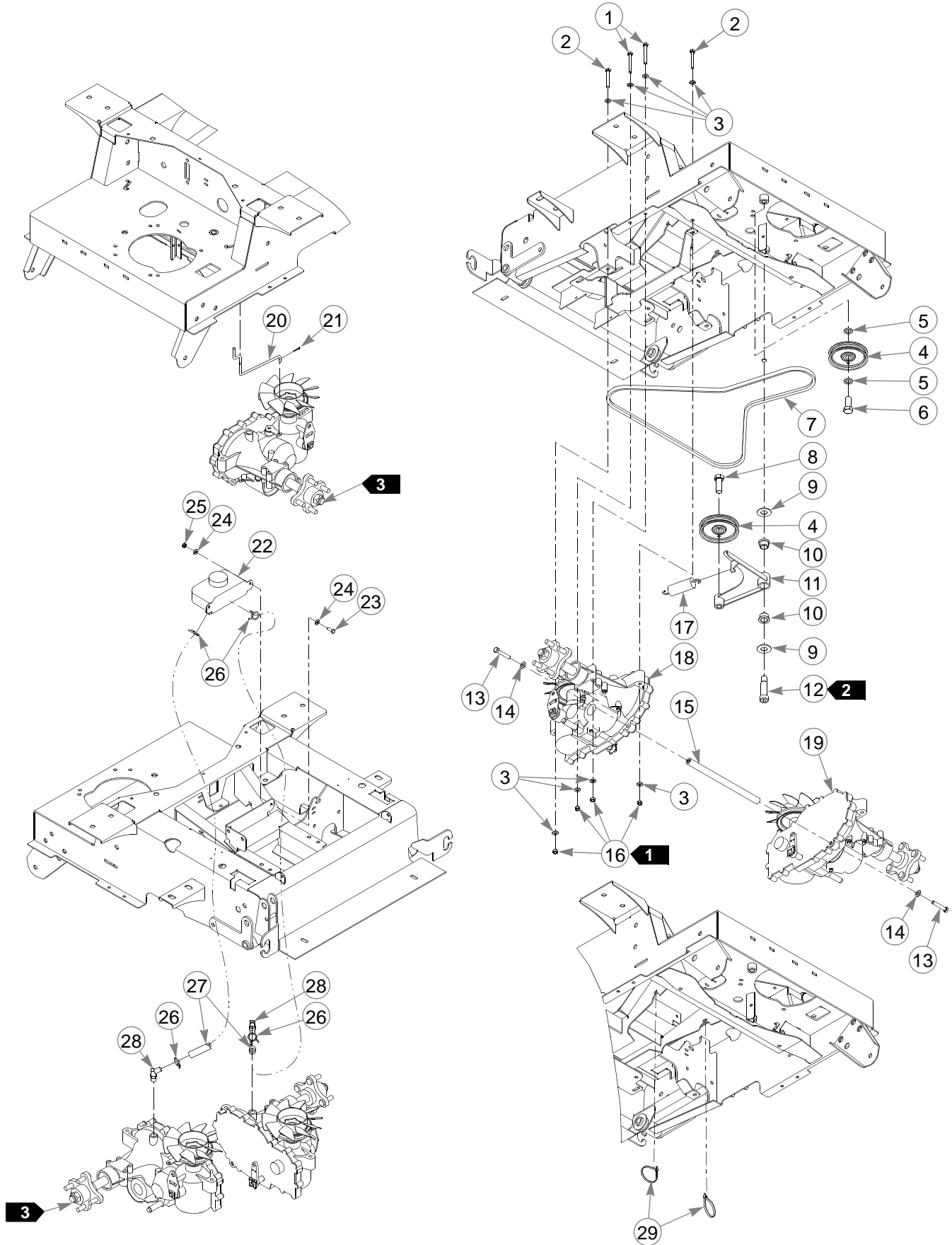

# Hydraulic System

INDEX NO.	PART NO.	QTY	DESCRIPTION
1	710087	4	CS .312-18 X 2.500 HX G5
2	038828	4	CS .312-18 X 2.250 HX G5
3	768523	16	FW .343 X .687 X .051/.080 HD ZN/YL
4	786848	2	IDLER PULLEY 4.0 OD
5	028118	2	FW .625 X 1.00 X .134 ZNYC
6	794446	1	CS .625-11 X 1.500 HX G5
7	600979	1	BELT, FASTRAK PUMP DRIVE
8	025007	1	CS .625-11 X 1.750 HX G5
9	025296	2	FW .760 X 1.625 X .08 ZNYC
10	781153	2	UHMW BUSHING
11	107881	1	PUMP IDLER W/A, FASTRAK
12	601084	1	SB .750 X 2.000 SH .625-11
13	016410	2	CS .375-16X2.00 G5 ZN
14	767954	2	FW .406 X .812 X .060 SAE
15	600987	1	ZT SPACER TUBE
16	034272	8	NT .312-18 HX G5 ZN
17	036384	1	SPRING 1/4 COIL PL 1.23
18	601404	1	ZT3100 LH
19	601403	1	ZT3100 RH
20	601088	2	TOW LINK ROD
21	048553	2	CP .062DX1.000 LG HML Z
22	600759	1	OVERFLOW TANK
23	055939	2	CS .250-20X.750 HX G5 ZN
24	768515	4	FW .281X.625X.051/.080 HD ZN/YL
25	068551	2	NT .250-20 HXZY NL
26	601001	4	SPRING CLAMP 3/4" DIA
27	601018	2	OVERFLOW HOSE
28	600880	2	HYDRAULIC FITTING 45 DEG
29	000331	2	WIRE TIE, SMALL/SHORT

## NOTES:

1. Torque to 23 N-m.
2. Torque to 136 N-m.
3. Torque axle hub nuts to 373 N-m.
4. Service parts available for the transaxles:

PART NUMBER	DESCRIPTION	PART NUMBER	DESCRIPTION
600767	OVERFLOW TANK CAP	601941	FAN/PULLEY KIT
600972	BRAKE ARM RETAINER CLIP	601221	ZT2800 BRAKE ARM - 2007
600974	RIGHT FILTER GUARD	601433	4-BOLT HUB KIT SDFST
600975	LEFT FILTER GUARD	600976	OIL FILTER ZT 2800

# Steering

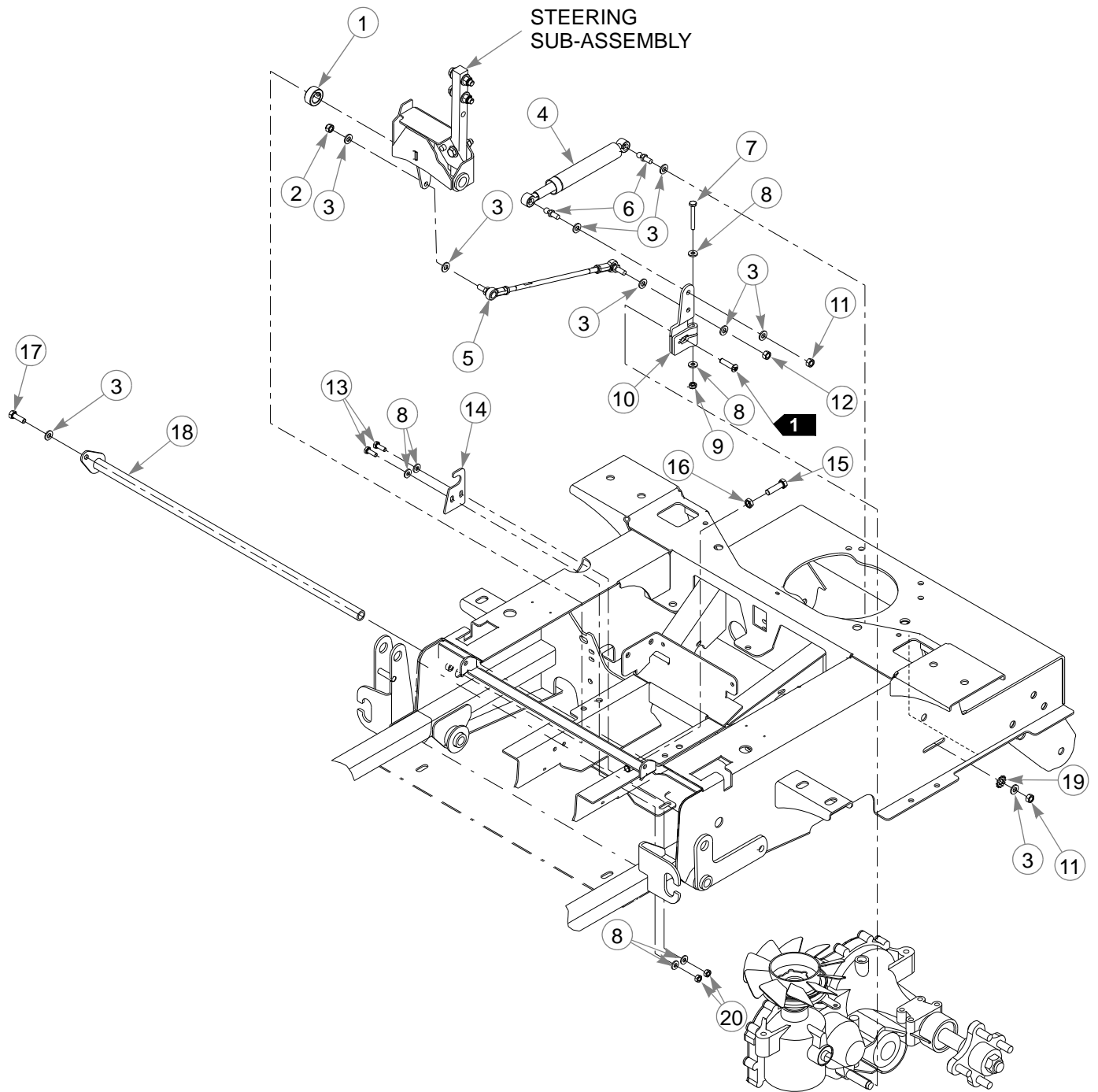



# Steering

INDEX NO.	PART NO.	QTY	DESCRIPTION
1	784439	2	LOCK COLLAR .750
2	023655	2	NT .312-24 HX NL ZN
3	768523	17	FW .343 X .687 X .051/.080 HD ZN/YL
4	600221	2	DAMPER, STEERING
5	600981	2	PUMP ROD ASSEMBLY
6	781922	4	BALL STUD, DAMPER
7	704163	2	CS .250-20 X 2.000 HX G5 ZN
8	768515	12	FW .281 X .625 X .051/.080 HD ZN/YL
9	068551	2	NT .250-20 HX ZN NL
10	109318	2	PUMP ARM
11	034272	4	NT .312-18 HX G5 ZNYC
12	041152	2	NT .312-24 HX ZNYC
13	055939	4	CS .250-20 X .750 HX G5 ZN
14	108968	2	STEER TUBE SUPPORT
15	005116	2	CS .375-16 X 1.375 HX G5 ZN
16	706168	2	NT .375-16 HX JAM GR5 ZN
17	036236	1	CS .312-18 X 1.000 HX G5 ZN
18	361295	1	PIVOT TUBE
19	029876	2	LW .312 INT-EXT TOOTH ZN
20	024927	4	NT .250-20 HX GR5 ZN

## NOTES:

1. Supplied with transmission.

## CONTROL LEVER ADJUSTMENT

The control levers can be adjusted for operator comfort. By loosening the nuts that attach the upper control lever to the lower lever (FIG. 1), the upper control lever can be pivoted to fit the operator's personal preference.

The control levers can also be adjusted up and down. Remove the hardware and slide the upper control lever up or down and align the holes in it with the holes in lower lever. Re-install the hardware and tighten.

The control levers should be adjusted so that they align with each other when in the neutral position (FIG. 2).

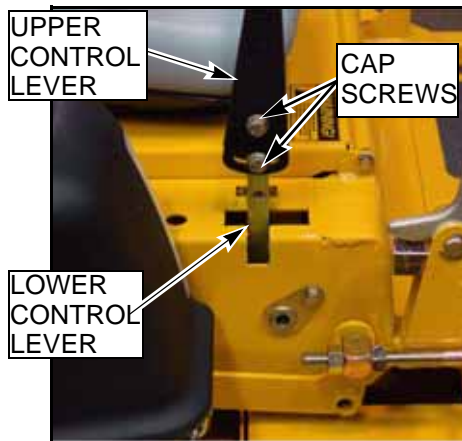

FIG. 1



FIG. 2

---

## STEERING LINKAGE

The neutral adjustment for the control levers in the neutral position is discussed in this section. The tractor steering has been factory adjusted to eliminate creeping when the control levers are in the neutral position (FIG. 3). However, should the tractor begin to creep, the control lever linkage can be adjusted as follows:



FIG. 3

### CONTROL LEVER NEUTRAL ADJUSTMENT

Before considering any adjustment, check the tire air pressure. Unequal tire pressure will cause the tractor to drift to one side. Refer to tire pressure information in the section of this manual.

**NOTE:** Proper park brake adjustment must be completed before the control lever neutral adjustment can be done.

Fine adjustment to the unit's steering is made with the transmission control rod. (FIG. 4).

Neutral is properly adjusted when the control levers are in the park brake position and the transmissions do not "whine".

If this occurs, the control linkage may be adjusted as follows:

1. Park the unit on a flat surface, raise the rear of the tractor and block with certified jack stands (FIG. 6). With the park brakes set, start the engine. Once the engine is started, if the transmissions whine while the park brake is engaged, then neutral needs to be reset. Turn off the engine.



**WARNING:** Never work under the machine or attachment unless it is safely supported with jack stands. Make certain machine is secure when it is raised and placed on the jack stands. The jack stands should not allow the machine to move when the engine is running and the drive wheels are rotating. **Use only certified jack stands.** Use only appropriate jack stands, with a minimum weight rating of 2000 pounds to block the unit up. Use in pairs only. Follow the instructions supplied with the vehicle stands.



**WARNING:** This is a dangerous operation - keep hands, hair, clothing, etc., clear of the cooling fans on top of the transmissions! **Exercise extreme caution.**



**WARNING:** Never attempt to make any adjustments or repairs to the tractor drive system while the engine is running. **The following procedures should be performed by trained maintenance personnel only.**

2. Loosen and back off the jam nuts on both ends of the steering control rod assembly (FIG. 4). Set the steering control lever in the neutral/brake position.
3. Remove the female spade connectors from the seat switch (located under the seat). These will need to be connected together now to bypass the seat switch to perform the following functions. **This must only be done by a qualified authorized dealer.**
4. Make sure the steering damper ball studs attached to the frame at the rear of the damper on either side are loose and allowed to slide in the slot.
5. Both steering control levers need to be in the brake position when starting the engine, but need to quickly be moved out of the brake position once engine is started so the

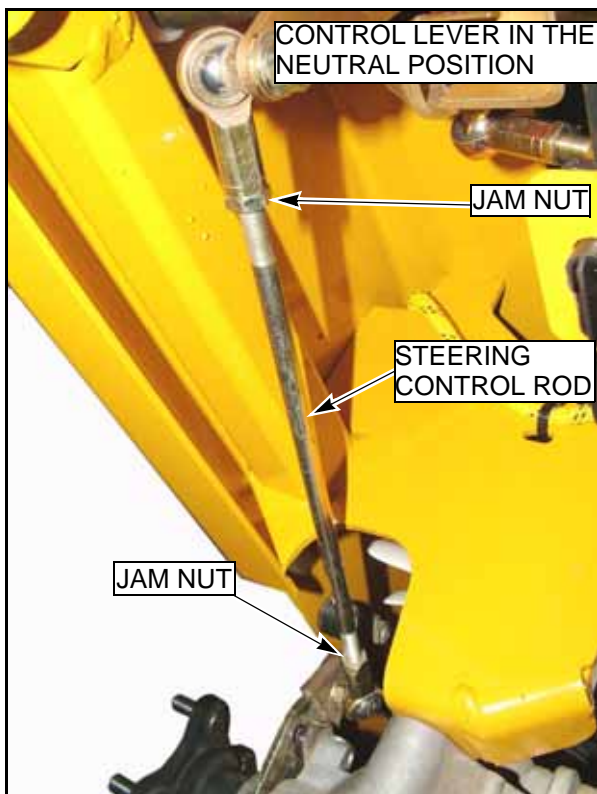

FIG. 4



FIG. 5

6. Start the engine. Move the control lever to just engage the brake (neutral) slot and hold it in that position (Do not engage the control lever far enough to engage the brakes in the brake slot) (FIG. 5).



**WARNING: This operation is extremely dangerous.** Pay close attention when adjusting the transmission control rod so you do not get your fingers, tools, or anything else close to the ZT 2800 transmission's cooling fans.

7. Beginning with the RH side of the tractor, adjust the steering control rod so that the RH drive axle just starts turning in the forward rotation while the steering lever remains in the neutral position. Now, turn the steering rod back the opposite direction to the point when the drive axle stops spinning. From that point, turn the steering rod back again  $\frac{1}{2}$  turn. This ensures that the steering rod is adjusted so that the transmission control arm is centered in the neutral band of the transmission.
8. Move the lever forward and backward and make sure that the drive axle spins forward and backward correctly. Return the steering lever to neutral and re-check to make sure the drive axle is stopped in the neutral position. Lock the steering control lever into the brake position. You should not hear the transmission whine if neutral is properly set.
9. Turn off the engine.
10. With the engine off, move the RH steering control lever into the neutral position and pull the lever all the way back to the rear of the tractor as if you were going full speed in reverse. Now, slowly bring the lever back to the neutral position and lock it into the brake position. This sets the steering damper in the correct neutral position. Tighten the ball stud at the rear of the damper that is attached to the frame side panel on the RH side (FIG. 7). Once this is tightened, you should be able to move the steering control lever to the reverse position, let it go, and the steering lever should return itself to the neutral position. This should finish the adjustment for the RH side steering control. Double check to make sure you have all fasteners tightened to the correct torque specifications.
11. Repeat steps 4 thru 9 for the LH side.
12. Once both sides are properly adjusted, double check them together to make sure everything is working properly.
13. **IMPORTANT:** With the engine off, disconnect the two female spade connectors from each other (from step #3) and reconnect them to the seat switch. This must be completed so the safety circuit is functioning properly. Refer to the machine's owner's manual for operation check.

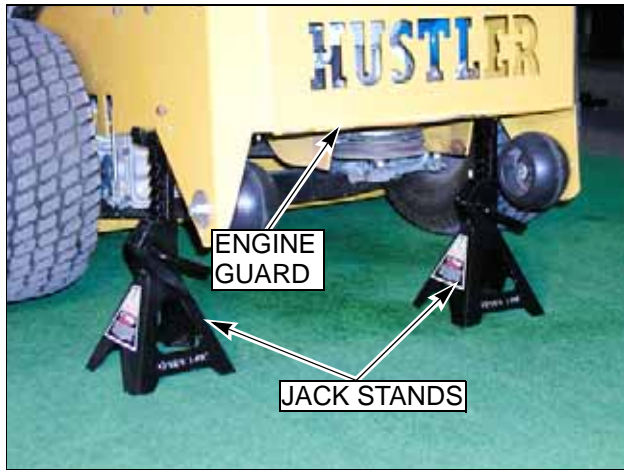

FIG. 6



FIG. 7



**WARNING:** Do not operate the tractor without plugging the tractor wiring harness into the seat switch. This switch is an important part of the safety start interlock system. Serious injury can result if the seat switch is not plugged into the tractor's wiring harness.

14. Check to make sure all tools or obstructions are removed from under the tractor. Assemble the drive wheels and wheel nuts. Torque the wheel nuts to 65-75 ft-lbs.
15. Jack up the rear of the tractor and remove the jack stands. Lower the tractor to the ground and remove the jack.
16. The control levers should be adjusted so that they align vertically with each other when in the neutral position (FIG. 2). Space between ends of control handles to be  $.50" \pm .25"$ .
17. Check the hydraulic oil level after final adjustments. Make sure oil level is within operating range specified.

### STEERING DAMPER

The steering damper (FIG. 7) is spring loaded to return the control levers to the neutral position from the reverse position. This gives the operator a sense of neutral during operation. If the tractor does not return to neutral from reverse then adjust as follows:

To set the steering dampers in the correct operating position follow these steps:

1. Shut engine off, place control levers in the park brake position, disengage deck clutch, remove ignition switch key and disconnect negative battery cable before doing any adjustments.
2. Place the control lever in the neutral position (FIG. 3).
3. Loosen the steering damper's rear ball stud (FIG. 7).
4. Pull the damper spring housing, to the rear, past the point that the internal spring is engaged.
5. Release the damper spring housing and allow the internal spring to bring the housing back to the neutral position.
6. Tighten the nut on the steering damper's rear ball stud.
7. To check, move the control lever to the reverse position and release. The control lever should return to the neutral position. If not, repeat steps 1 through 6.

### DRIVE STRAIGHT ADJUSTMENT:

1. Initially adjust cap screws (FIG. 8) all the way in so that the steering levers may go fully forward.
2. Drive tractor in an open area with both steering handles fully forward. The tractor will likely drift slightly to the left or right.
3. Whichever direction the tractor turns is the slow side. Leave the slow side cap screw and jam nut so that they are flush with the frame. Holding the cap screw in place, lock the jam nut.
4. On the fast side, through several iterations, back out the cap screw gradually until the fast side is slowed to the same speed as the other side and the tractor drives straight. After adjustment is finished, hold the cap screw still and tighten the jam nut.

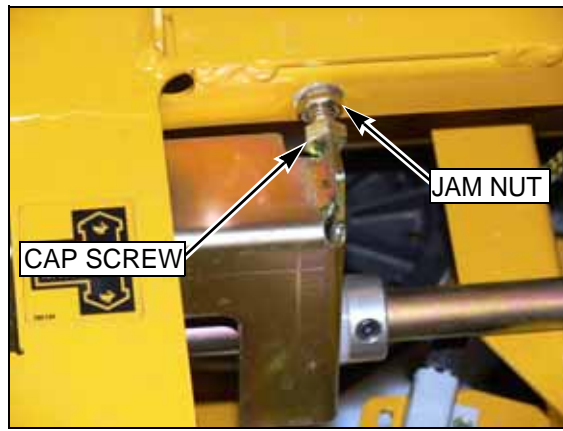
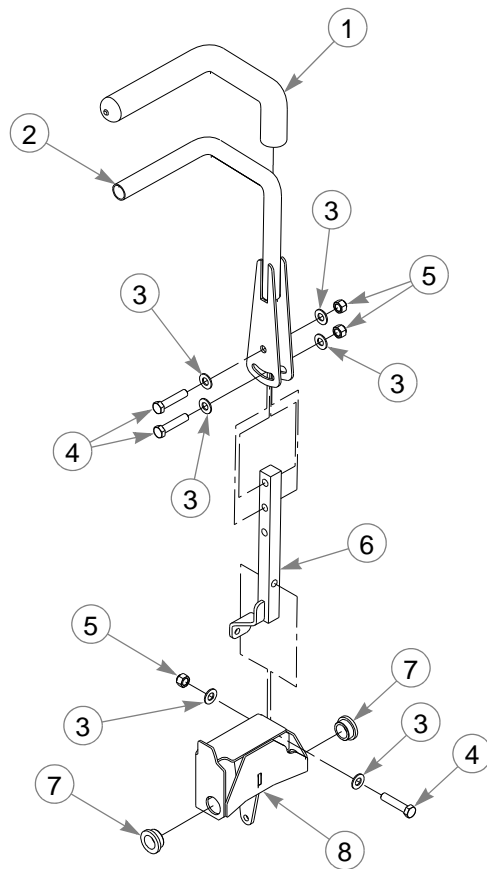

FIG. 8

# Steering Sub-Assembly



INDEX NO.	PART NO.	QTY.	DESCRIPTION
1	781260	1	STEERING BAR GRIP
<b>1</b> 2	360487	1	STEERING BAR
3	767954	12	FW .406 X .812 X .060 SAE HD ZN
4	705178	3	CS .375-16 X 1.750 HX G5
5	086660	6	NT .375-16 HXZY NL
6	107843	1	STEERING ARM LEFT (SHOWN)
	107842	1	STEERING ARM RIGHT
7	770867	2	BUSHING, PLASTIC .750X1
8	107848	1	STEER PIVOT, LEFT (SHOWN)
	107847	1	STEER PIVOT RIGHT

## NOTES:

1. Includes Item 1 (Steering Bar Grip).

---

**This page intentionally left blank.**

# **Brake**

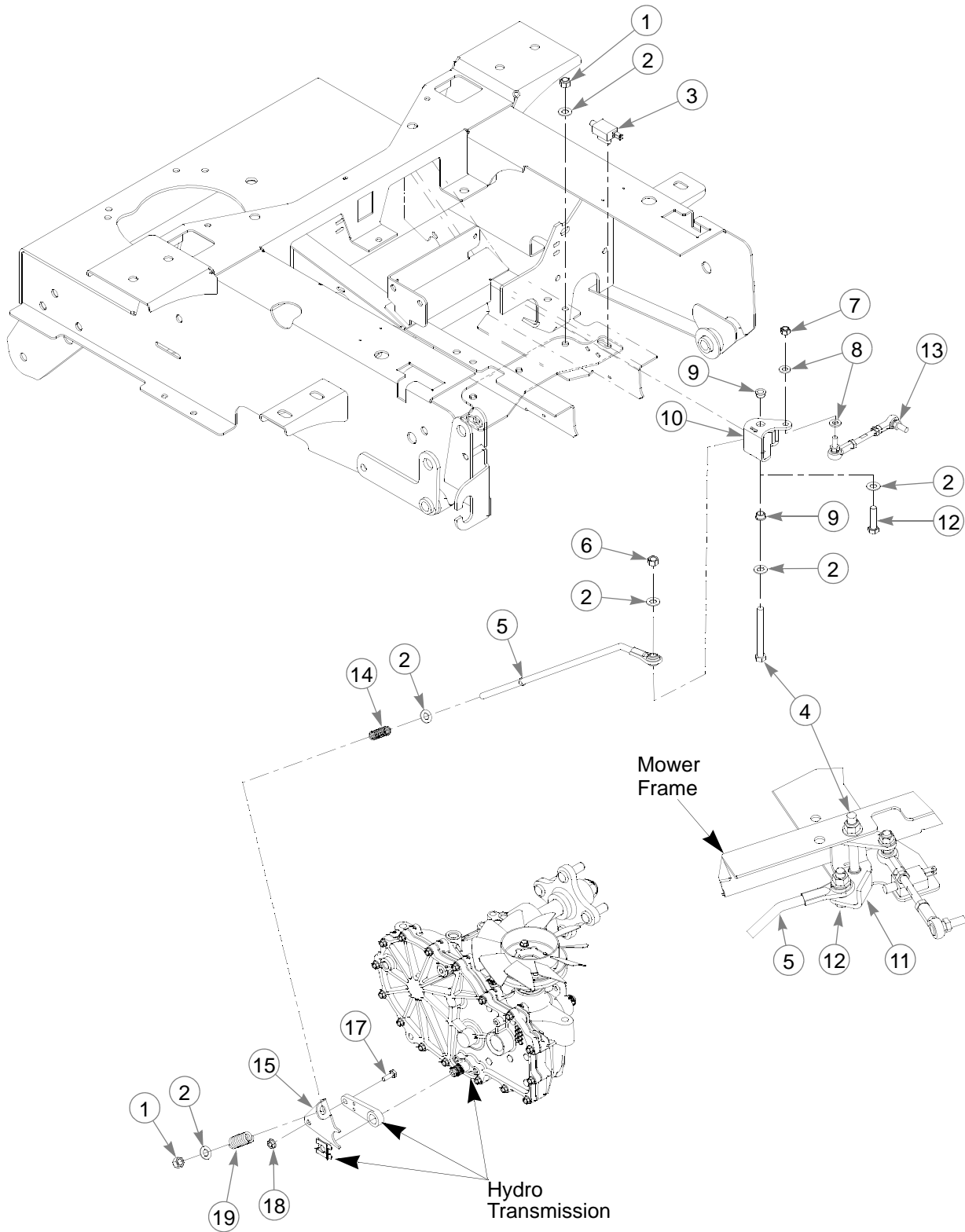



# **Brake**

INDEX NO.	PART NO.	QTY.	DESCRIPTION
1	086660	4	NT .375-16 HX LK NY
2	767954	12	FW .406 X .812 X .060 SAE HD ZN
3	601087	2	PLUNGER SWITCH
4	005108	2	CS .375-16X3.50 HX G5 Z
5	601410	2	BRAKE ROD ASSEMBLY
6	054502	2	NT .375-16 HX GRD 5 ZN
7	023655	4	NT .312-24 HXZY NL
8	768523	8	FW .34 3X .687 X .051/.080 HD ZN/YL
9	765339	4	BUSHING
10	107893	1	BRAKE BELL CRANK LS
11	107892	1	BRAKE BELL CRANK RS
12	080655	2	CS .375-16X1.500 HX G5
13	600991	2	SHORT BRAKE LINK ROD
14	601131	2	BRAKE ARM RET. SPRING
15	109203	1	BRAKE SPRING LINK LS
16	109202	1	BRAKE SPRING LINK RS (NOT SHOWN)
17	055939	2	CS .250-20X .750 HX G5
18	016816	2	NT .250-20 HX FL LK ZNY
19	601051	2	OVERTRAVEL SPRING

## NOTES:

### PARK BRAKE SPRING ADJUSTMENT

Occasionally check the park brake spring adjustment using the following method:

1. Shut engine off, place control levers in the park brake position, disengage deck clutch, remove ignition switch key and disconnect negative battery cable before doing any adjustments.
2. Position the control lever in the park brake position.
3. Measure the park brake spring. It should be compressed to 1-7/16". If it is not, adjust the nylock nut until the proper spring compression is achieved (FIG. 9).

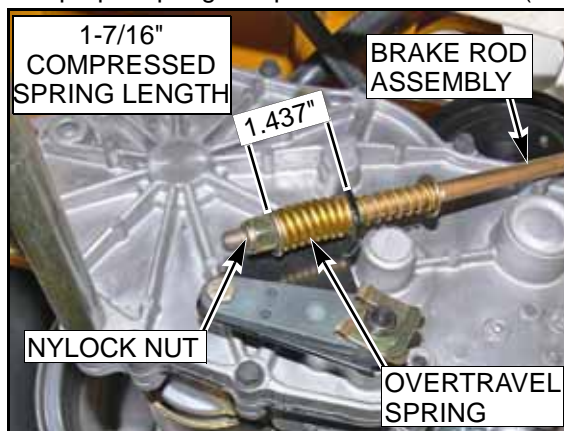

FIG. 9

4. Repeat for the other side.



---

## Section 4

Wheel and Tire . . . . .	4-2
Drive Wheel Breakdown . . . . .	4-4

# Wheel and Tire

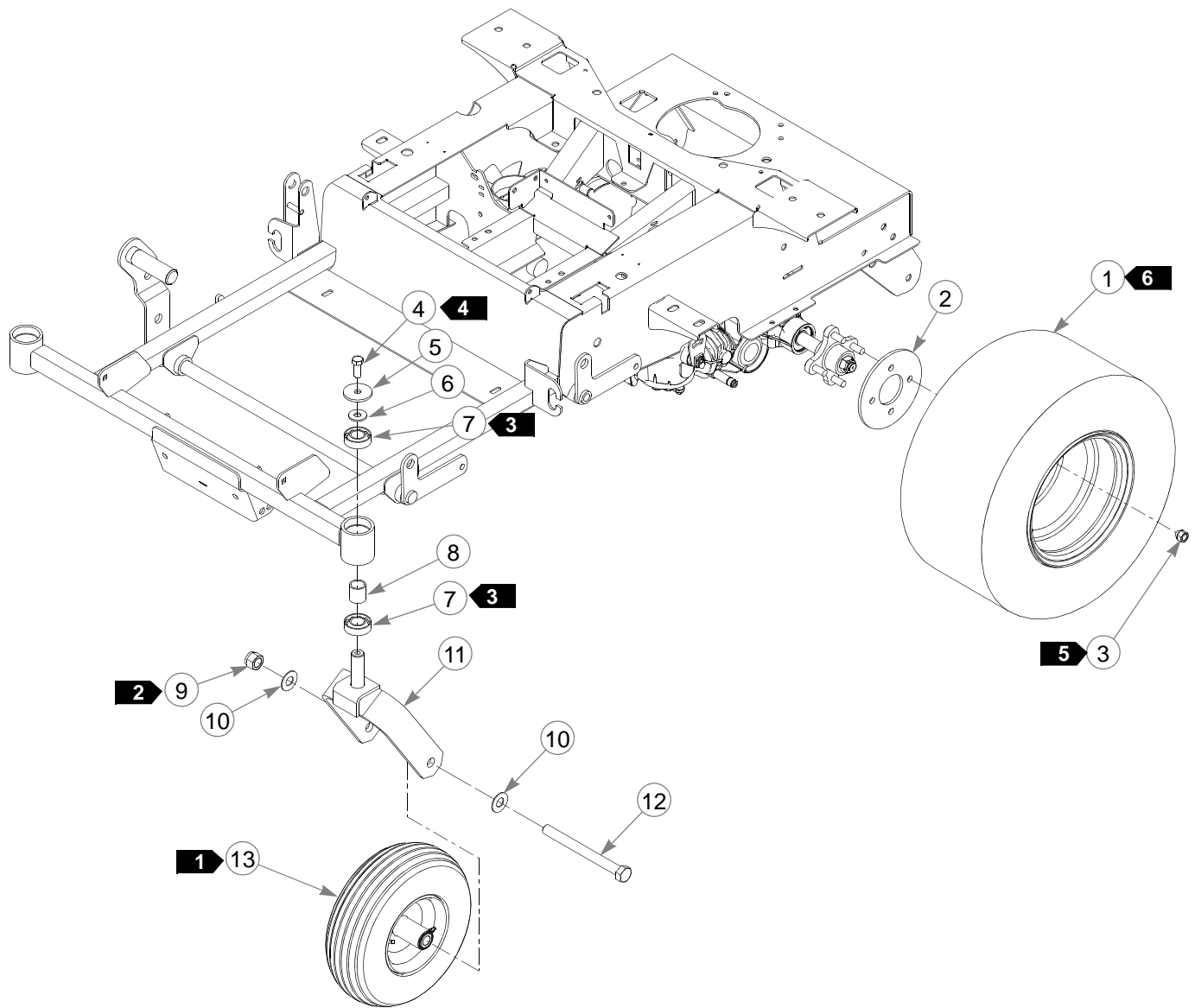

---

## **Wheel and Tire**

INDEX NO.	PART NO.	QTY.	DESCRIPTION
1	601349	2	TIRE/WHEEL 20 X 12-10 (ONLY USED ON 928382CE)
	600668	2	TIRE/WHEEL 20 X 10-10 (ONLY USED ON )
2	111875	2	BACKUP PLATE, WHEEL
3	061077	8	WHEEL NUT
4	705954	2	CS .500-13 X 1.25 HX G5 ZN
5	344267	2	FW .510 X 2.15 X .187 SPL ZN
6	712976	2	FW .531 X 1.375 X .125 ZNYC
7	784223	4	BEARING W/O COLLAR
8	784603	2	SPACER
9	061101	2	NT .750-10 HX NL ZN
10	025296	4	FW .760 X 1.625 X .08 ZN
11	366625	2	FORK
12	786731	2	CS .750-10 X 8.00 HX GR5 ZNYC
13	786061	2	WHEEL & TIRE ASSY

---

### **NOTES:**

1. Apply grease to zerks (see owners manual).
2. Tighten, then back off until wheel spins freely.
3. Assemble with extended inner race down.
4. Apply Loctite® 242 to threads.
5. Torque to 88.1-101.7 Nm.
6. Inflate tires to 55.16–82.74kPa.

# Drive Wheel Breakdown

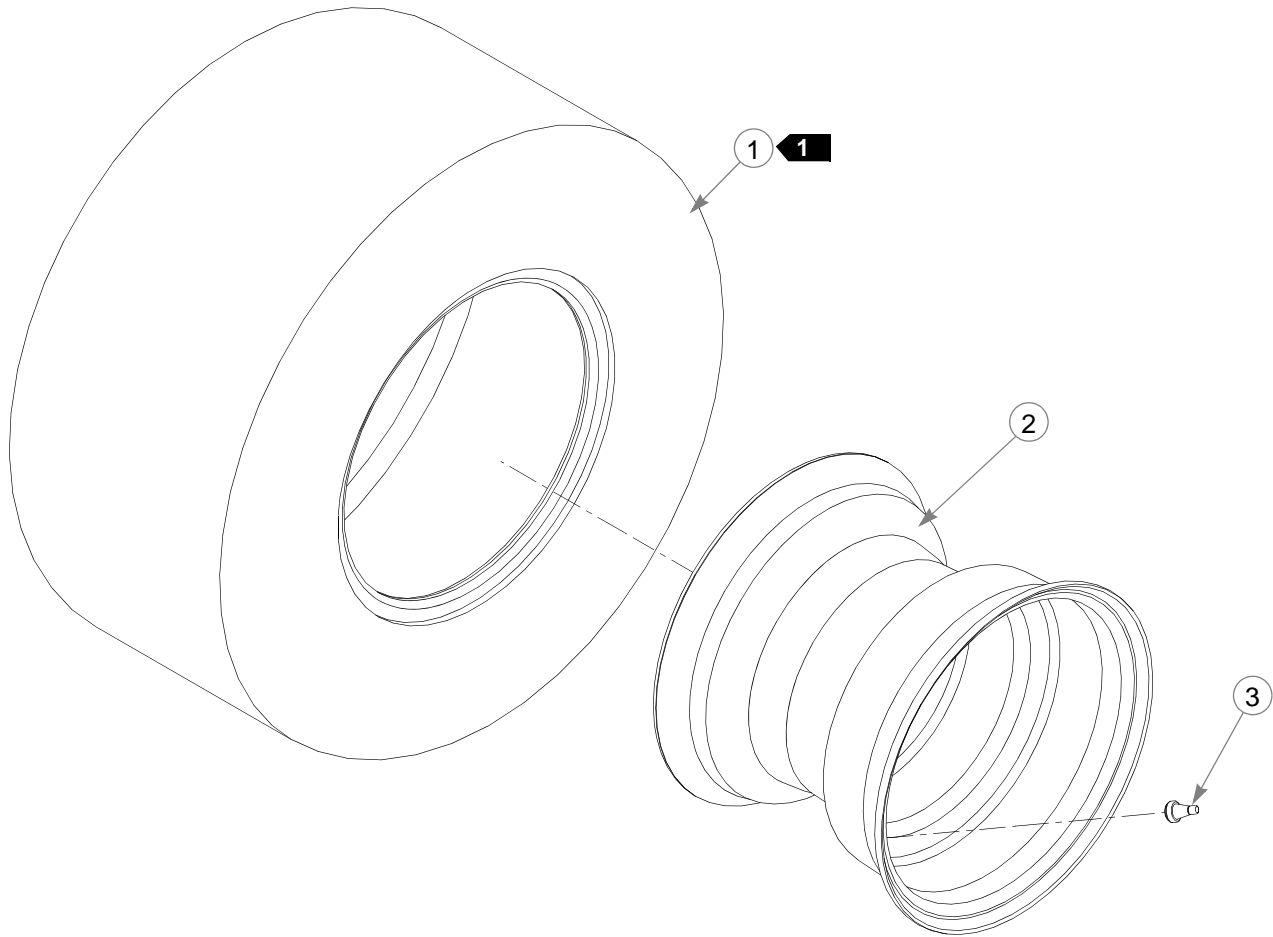

INDEX NO.	PART NO.	QTY.	DESCRIPTION
1	601348	1	TIRE 20 X 12-10 ( 60" & 54" MOWER)
2	601347	1	WHEEL ( 60" & 54" MOWER)
3	019521	1	TIRE VALVE

1	600684	1	TIRE 20 X 10-10 ( 48" MOWER)
2	600700	1	WHEEL ( 48" MOWER)
3	019521	1	TIRE VALVE

## NOTES:

1. Inflate tire to 88.1-101.7 kPa.

---

## Section 5

Engine, 23 HP Kaw .....	5-2
Fuel .....	5-6

# Engine, 23 HP Kaw

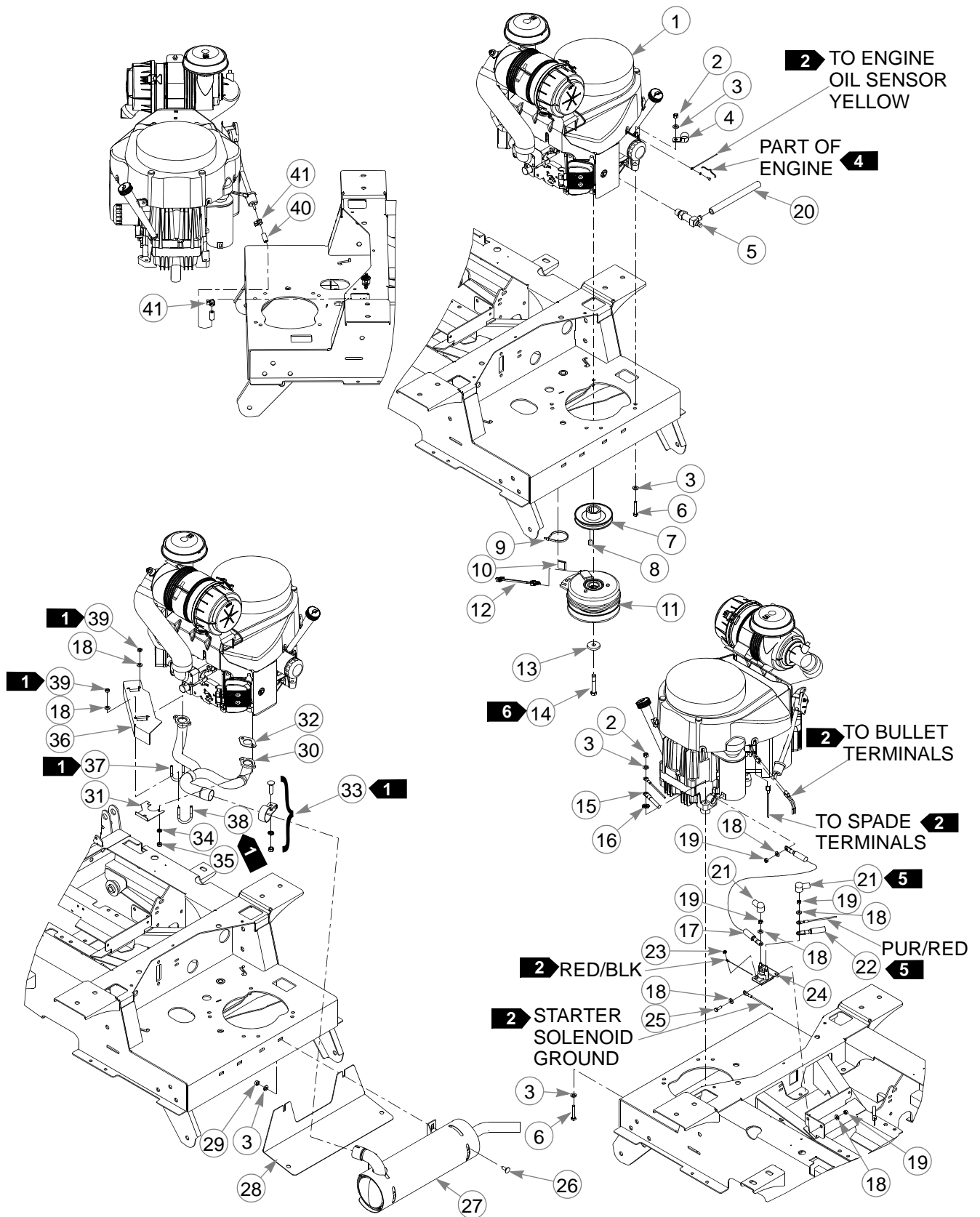



---

## **Engine, 23 HP Kaw**

ITEM NO.	PART NO.	QTY	DESCRIPTION
1	N/A	1	KAWASAKI 23HP ENGINE
2	058776	4	NT .312-18 HXZY NL
3	768523	10	FW .343 X .687 X .051/.080 HD ZN/YL
4	043570	1	HOSE CLIP
5	796524	1	OIL DRAIN VALVE M20X2.5
6	050161	4	CS .312-18 X 1.750 HX G5
7	783761	1	SINGLE PULLEY
8	712372	1	KEY 1/4 SQ X 0.66 LG
9	000331	5	WIRE TIE SMALL/SHORT
10	784918	1	RUBBER BUMPER
11	601326	1	WARNER CLUTCH
12	791251	1	CLUTCH PIGTAIL
13	763417	1	FW .454 X 1.50X.250
14	785659	1	CS .437-20 X 2.50 HX G5 Z
15	796219	1	NEG. BATTERY CABLE 36"
16	029876	1	LW .312 INT-EXT TOOTH ZN
17	601062	1	POS BATTERY CABLE 17"
18	768515	11	FW .281 X .625 X .051/.080 HD ZNYC
19	024927	5	NT .250-20 HX GR.5 ZNYC
20	104786	1	OIL DRAIN HOSE
21	601319	2	POS BATTERY CABLE BOOT
22	601312	1	POS BATTERY CABLE 4"
23	044255	1	NT #10-32 HX ZN
24	030817	1	STARTER SOLENOID
25	055939	2	CS .250-20X .750 HX G5
26	016253	2	CB .312-18X .750 FUL ZN
27	601002	1	HORIZONTAL MUFFLER
28	108969	1	MUFFLER HEAT SHIELD
29	034272	2	NT .312-18 HX G5 ZN
30	601004	1	EXHAUST MANIFOLD
31	108288	1	HEAT SHIELD
32	780841	2	KAW MUFFLER GASKET
33	785378	1	1.50" MUFFLER CLAMP
34	017004	4	LW .312 MED SPRING ZNYC
35	782664	4	NT M8-1.25 HX STAINLESS
36	109338	1	HEATSHIELD FST KAW675CC
37	601429	1	UBOLT .250-20 X 1.125 DIA
38	601452	1	UBOLT .250-20 X 1.250 ID
39	024927	4	NT .250-20 HX GR.5 ZNYC
40	015818	13"	1/4" FUEL LINE
41	000323	2	HOSE CLAMP CLIP

---

### **NOTES:**

1. Includes mounting hardware.
2. Part of Wire Harness.
3. Engine oil capacity:Refer to engine owner's manual.

- 
4. Supplied with engine.
  5. Route item 22 (4" positive battery cable) with the purple and red wires through item 21 (positive battery cable boot) prior to fastening hardware to the solenoid.
  6. Torque to 61–65 Nms. If fastener is loosened or removed, do not re-use. Replace with new fastener. Use only hand tools to install this fastener.

ENGINE SPEED	
MODEL NO. ENDING IN:	HIGH IDLE
CE	2550±50 RPM

⚡

---

**This page intentionally left blank.**

# Fuel

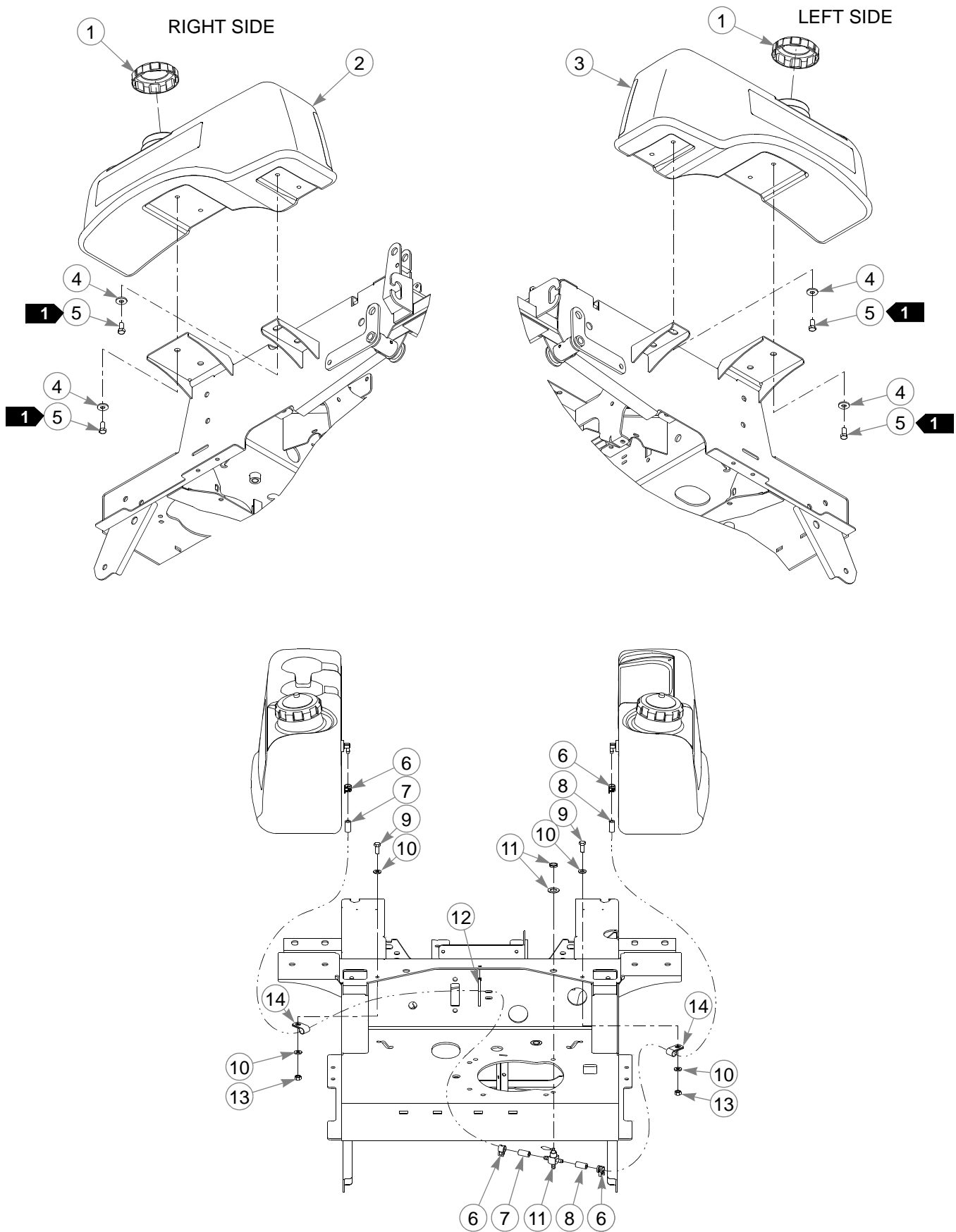

---

# **Fuel**

INDEX NO.	PART NO.	QTY	DESCRIPTION
1	779306	2	FUEL CAP 3.5"
2	601320	1	FUEL TANK RIGHT SIDE
3	601321	1	FUEL TANK LEFT SIDE
4	712919	8	FW .406 X 1.00 X .12 HRD ZN
5	055822	8	CS .375-16 X .75 HX G5
6	000323	4	HOSE CLAMP CLIP
7	015818	24"	1/4" FUEL LINE
8	015818	11"	1/4" FUEL LINE
9	034280	2	CS .312-18 X .750 HX G5 ZN
10	768523	4	FW .343 X .687 X .051/.080 HD ZN/YL
11	745059	1	FUEL VALVE 3-WAY
12	000331	1	WIRE TIE, SMALL/SHORT
13	034272	2	NT .312-18 HX G5 ZN
14	000398	2	CLAMP

---

## **NOTES:**

1. Torque to 27 N-m.



---

## Section 6

Battery . . . . .	6-2
Instrument Panel . . . . .	6-4
Electrical Schematic—601341 . . . . .	6-6

# Battery

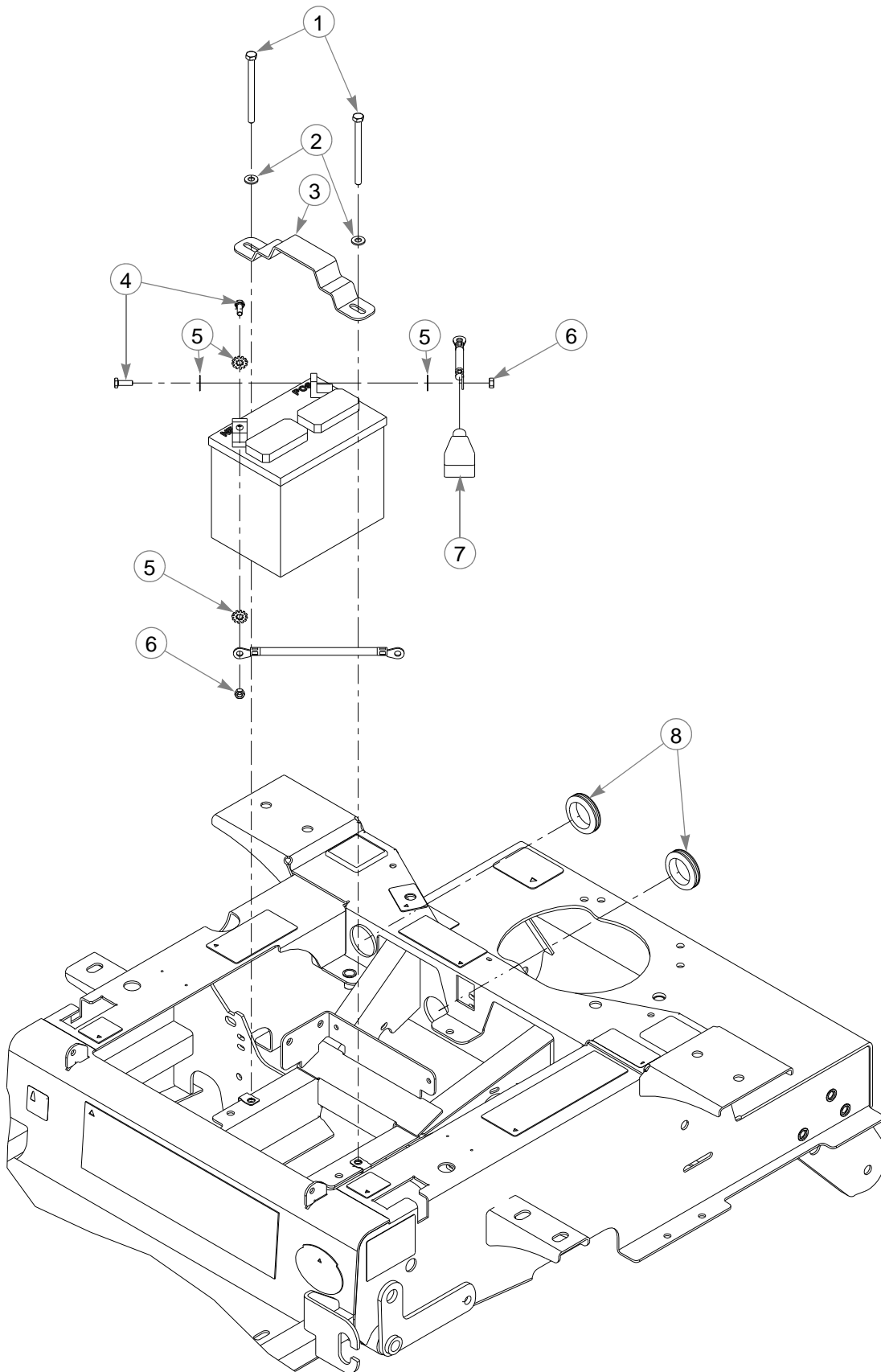



---

# **Battery**

INDEX NO.	PART NO.	QTY.	DESCRIPTION
1	714618	2	CS .312-18X4.000 HX G5
2	768523	2	FW .343X.687X.051/.080H
3	348417	1	STRAP, BATTERY CLAMP
4	055939	2	CS .250-20X .750 HX G5
5	029868	4	LW .250 INT-EXT TOOTH Z
6	024927	2	NT .250-20 HX GR.5 ZNYC
7	771428	1	BATTERY CBL BOOT-RED(FS)
8	794644	2	GM 1.50 X 2.12 X 1.75

---

## **NOTES:**

# Instrument Panel

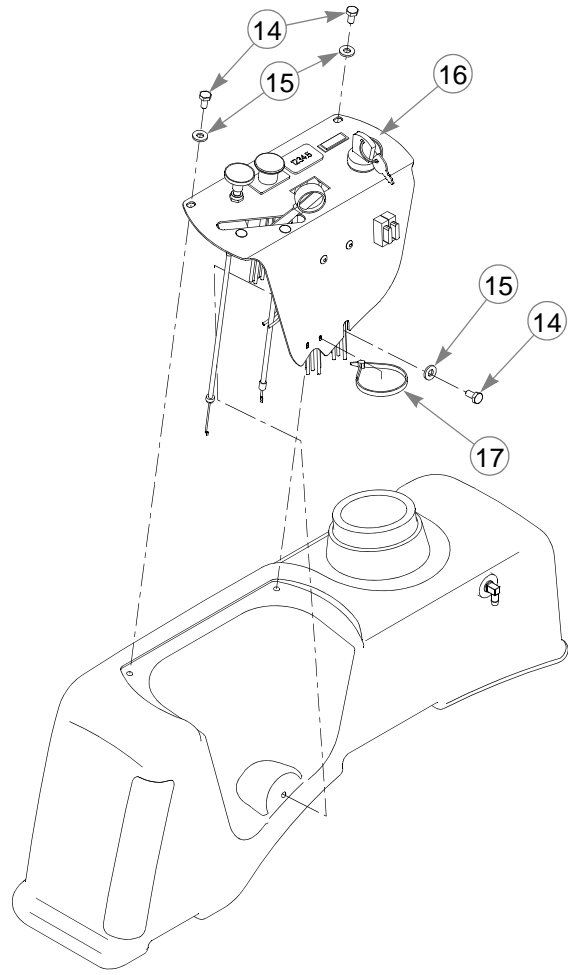
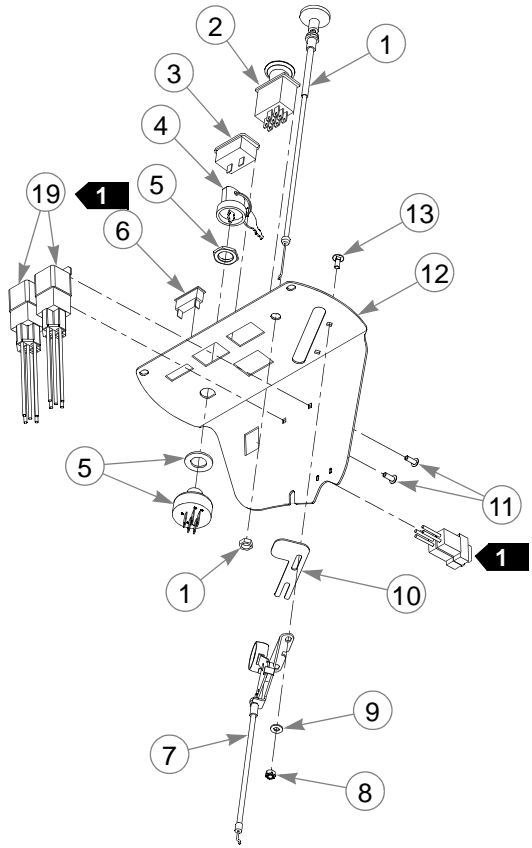

## FUSE SIZE AND LOCATION

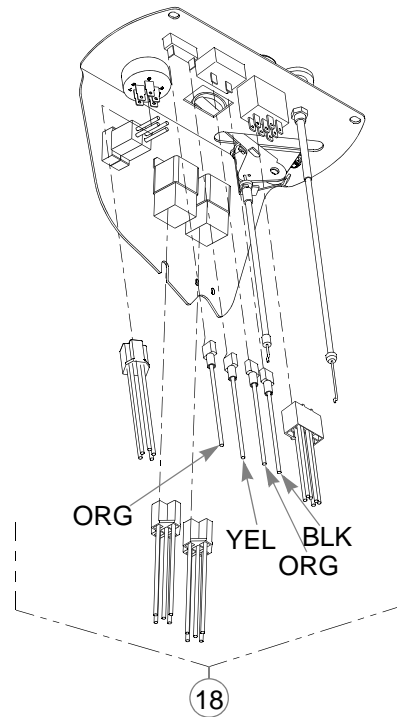
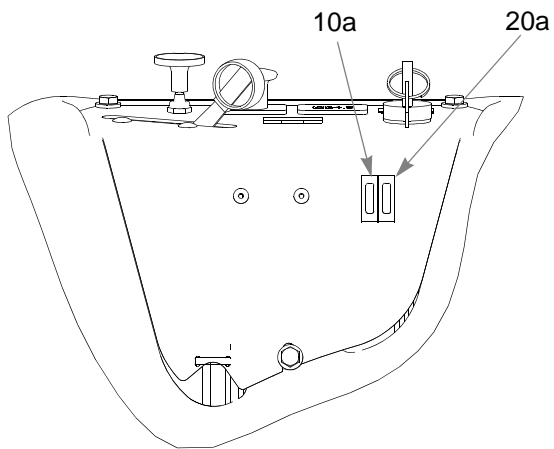

---

## **Instrument Panel**

INDEX NO.	EXCEL P/N	QTY	DESCRIPTION
1	601095	1	CABLE, CHOKE
2	776476	1	SWITCH, PTO
3	769166	1	HOUR METER
4	785808	1	KEY ASSEMBLY
5	045898	1	IGN SWITCH
6	712257	1	INDICATOR LIGHT, RED
7	601094	1	CABLE, THROTTLE
8	059832	2	NT #10-24 HX NL ZN
9	704932	2	FW .219 X .500 X .048 ZNYC
10	102707	1	STOP, CE THROTTLE
11	601089	2	RIVET .188 DIA. BLK HD
12	550454	1	INSTRUMENT PANEL
13	601098	2	CB 10-24 X .500 ZYNC
14	055947	3	CS .250-20X .500 HX G5 ZN
15	768515	3	FW .281 X .625 X .051/.080 HD ZN/YL
16	602233	1	DECAL, INST PANEL
17	000331	6	WIRE TIE, SMALL/SHORT
18	601341	1	WIRE HARNESS, FST KAW
19	026237	2	RELAY

---

### **NOTES:**

1. Part of wiring harness.
2. Item 11 includes 602233 (Dash Decal)

# Electrical Schematic—601341

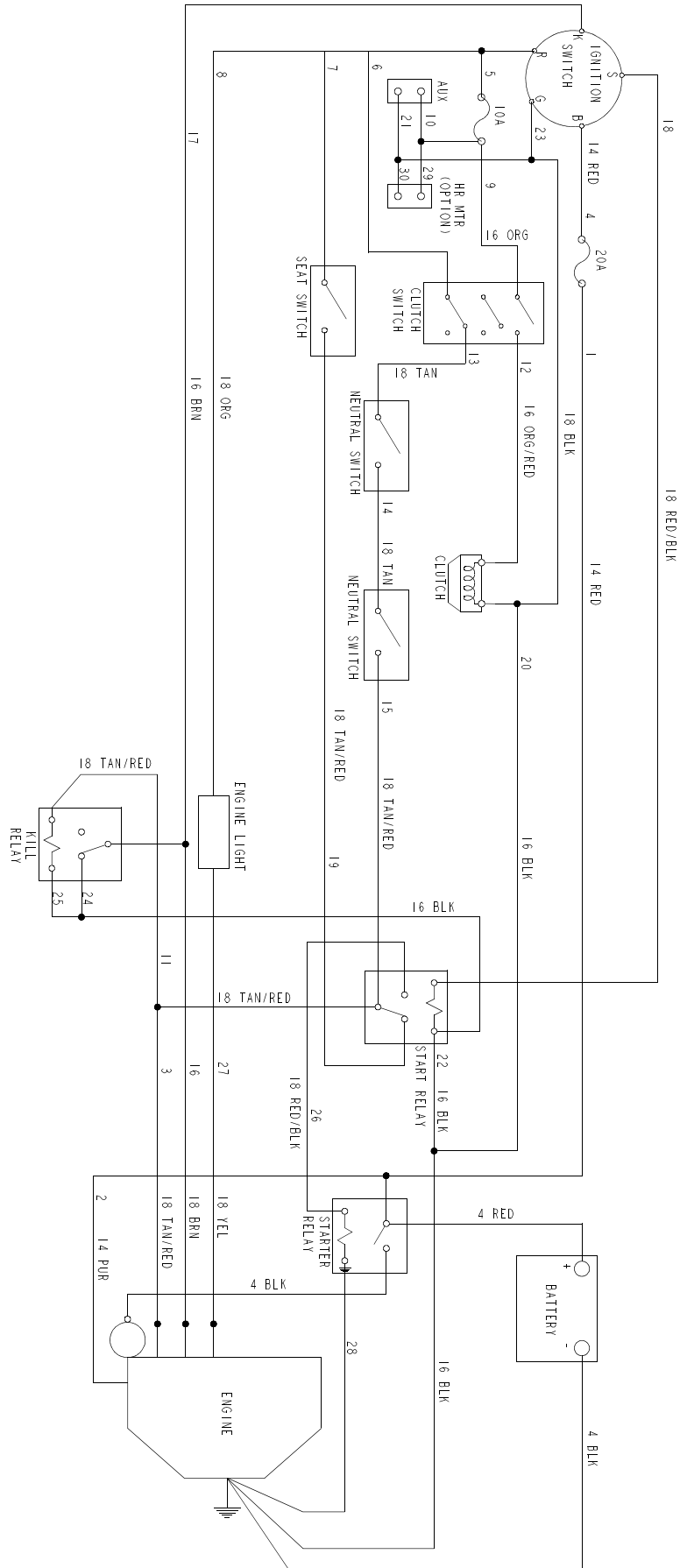

---

## Section 7

54" Deck Decals . . . . .	7-2
54" Deck Pulley Assembly . . . . .	7-4
54" Deck . . . . .	7-8
54" Deck Belt Routing and Tensioning . . . . .	7-10
Deck Lift . . . . .	7-12
Deck Mounting Hardware . . . . .	7-14

# **54" Deck Decals**

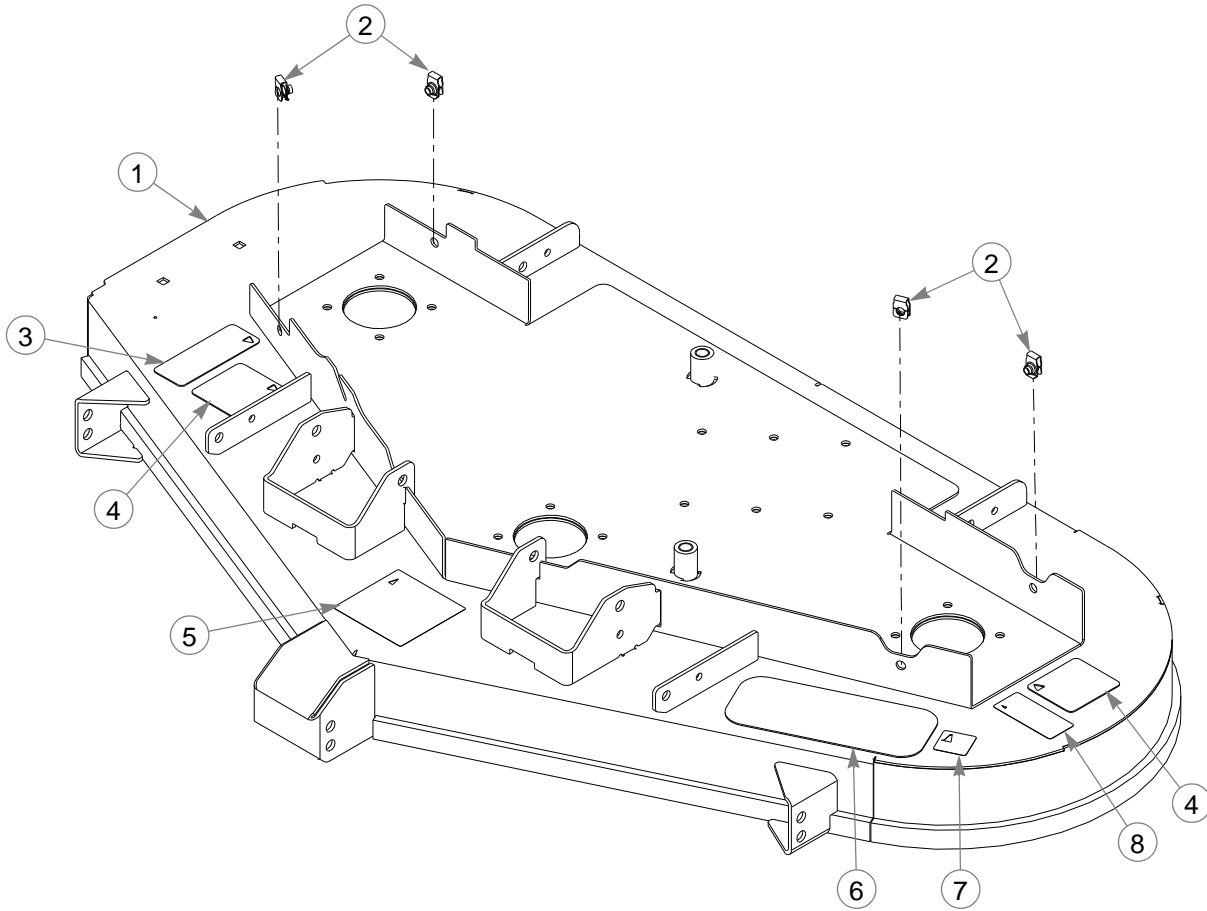

INDEX NO.	PART NO.	QTY.	DESCRIPTION
1	550233	1	54" DECK WELDMENT
2	601069	4	CN .312-18X.200 MAX THK
3	601624	1	DISCHARGE CHUTE DECAL
4	601837	2	DECK DANGERS DECAL
5	781419	1	DECK BELT ROUTING DECAL
6	785055	1	STEP TREAD
7	727172	1	'MADE IN U.S.A.' DECAL
8	601892	1	THROWN OBJECTS DECAL

### **NOTES:**

1. Item 1 (550233) includes Items 2–8 as a service deck.

---

**This page intentionally left blank.**

# 54" Deck Pulley Assembly

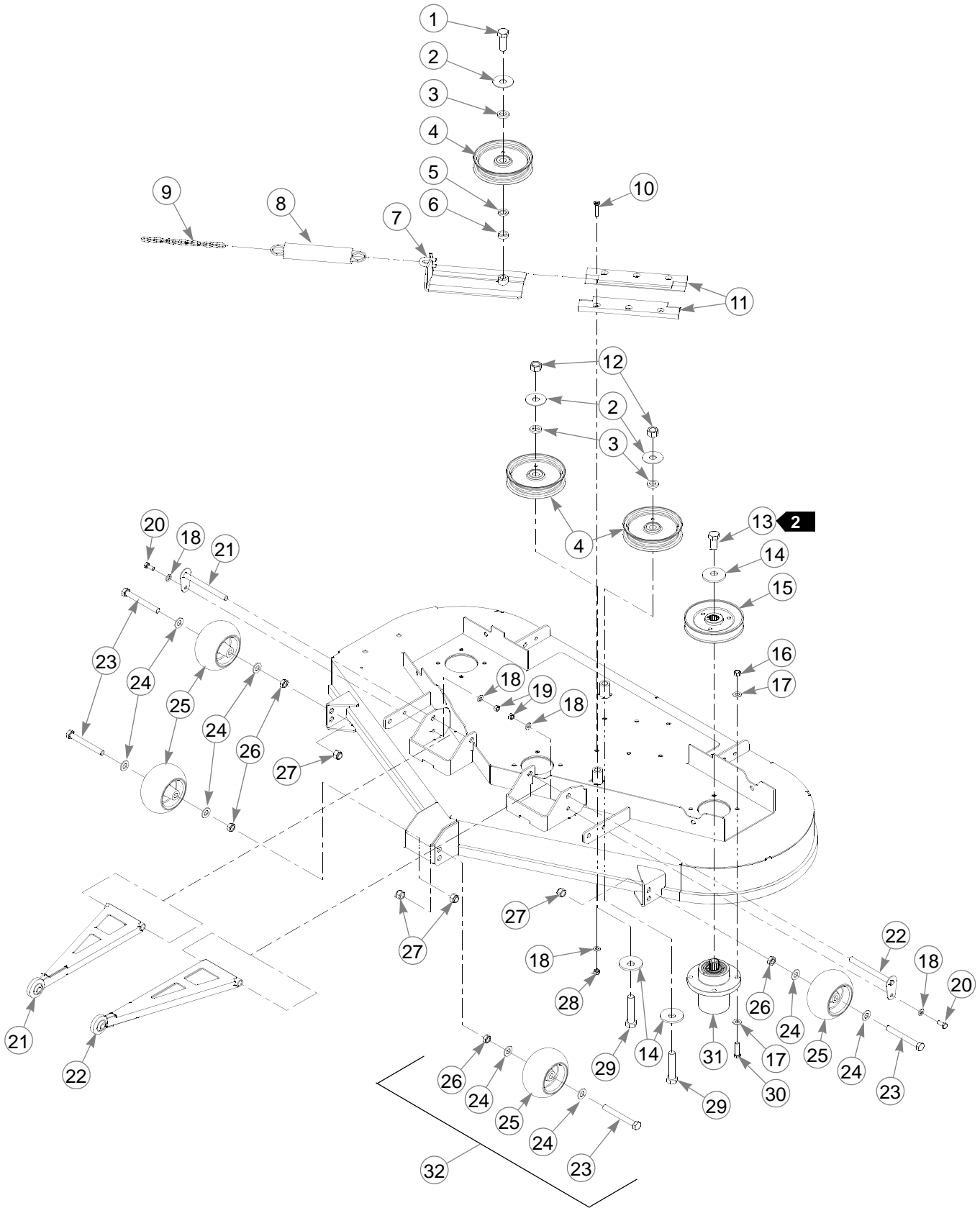



---

# **54" Deck Pulley Assembly**

INDEX NO.	PART NO.	QTY.	DESCRIPTION
1	025007	1	CS .625-11X1.750 HX G5
2	046821	3	FW .656X 2.00X.078 ZNYC
3	797449	3	FW .650X1.125X.18 ZNYCG5
4	781856	3	IDLER PULLEY NHI 5.00"
5	028118	1	FW .625X1.00X.134 ZNYC
6	600296	1	DECK IDLER SPACER
7	350884	1	IDLER W/A
8	781302	1	IDLER SPRING
9	259812	1	CHAIN DECK LIFT SPRING
10	797910	6	CS .312-18X1.50FLT SH ZY
11	601434	2	UHMW IDLER SLIDE
12	016972	2	NT .625-11 HX G5 ZNYC
13	781872	3	CS .625-11X1.25 HX G5 Z
14	782474	5	CW .631 2.250X .187 PNT
15	786889	3	DECK DRIVE PULLEY
16	054502	12	NT .375-16 HX GRD 5 ZNY
17	767954	24	FW .406X .812 X.060 SAE
18	768523	10	FW .343X.687X.051/.080H
19	034272	2	NT .312-18 HX G5 ZNYC
20	034280	2	CS .312-18X .750 HX G5
21	109247	1	RIGHT PULLER & PIN ASSY
22	109248	1	LEFT PULLER & PIN ASSY
23	781708	4	CS .500-13X4.250 HX G5
24	767962	8	FW .531X 1.063X.090 SAE
25	031997	4	ANTI-SCALP WHEEL
26	053199	4	NT .500-13 HX JAM ZNYC
27	781567	4	NT .500-13 HX G8 ZY NL
28	058776	6	NT .312-18 HXZY NL
29	783738	2	CS .625-11X3.00 FULL HX
30	005116	12	CS .375-16X1.375 HX G5
31	783506	3	BLADE SPINDLE ASSEMBLY
 32	788166	4	ANTI SCALP WHEEL ASSY

---

## **NOTES:**

1. 788166 (Anti-scalp Wheels) include Items 23–26.
2. Torque to 160 Nm.

# 54" Deck Pulley Assembly

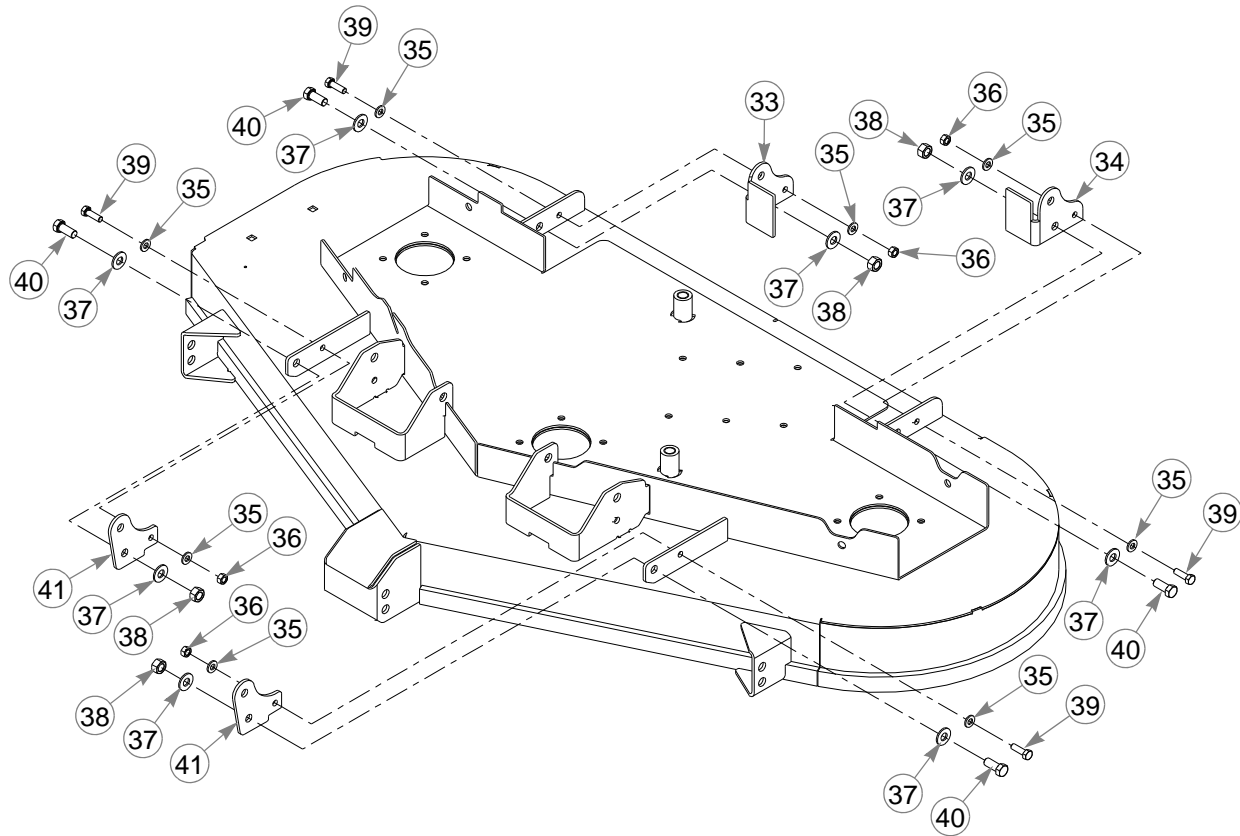

INDEX NO.	PART NO.	QTY.	DESCRIPTION
33	109239	1	HANGER EXT REAR RIGHT SIDE
34	109238	1	HANGER EXT REAR LEFT SIDE
35	768523	8	FW .343X.687X.051/.080H
36	034272	4	NT .312-18 HX G5 ZNYC
37	728147	8	FW .468X 1.00X.090 HT T
38	041707	4	NT .437-14 HX G5 ZNYC
39	036236	4	CS .312-18X1.000 HX G5
40	047746	4	CS .437-14X1.000 HX G5
41	109200	2	HANGER EXT FRONT

## NOTES:

---

**This page intentionally left blank.**

# 54" Deck

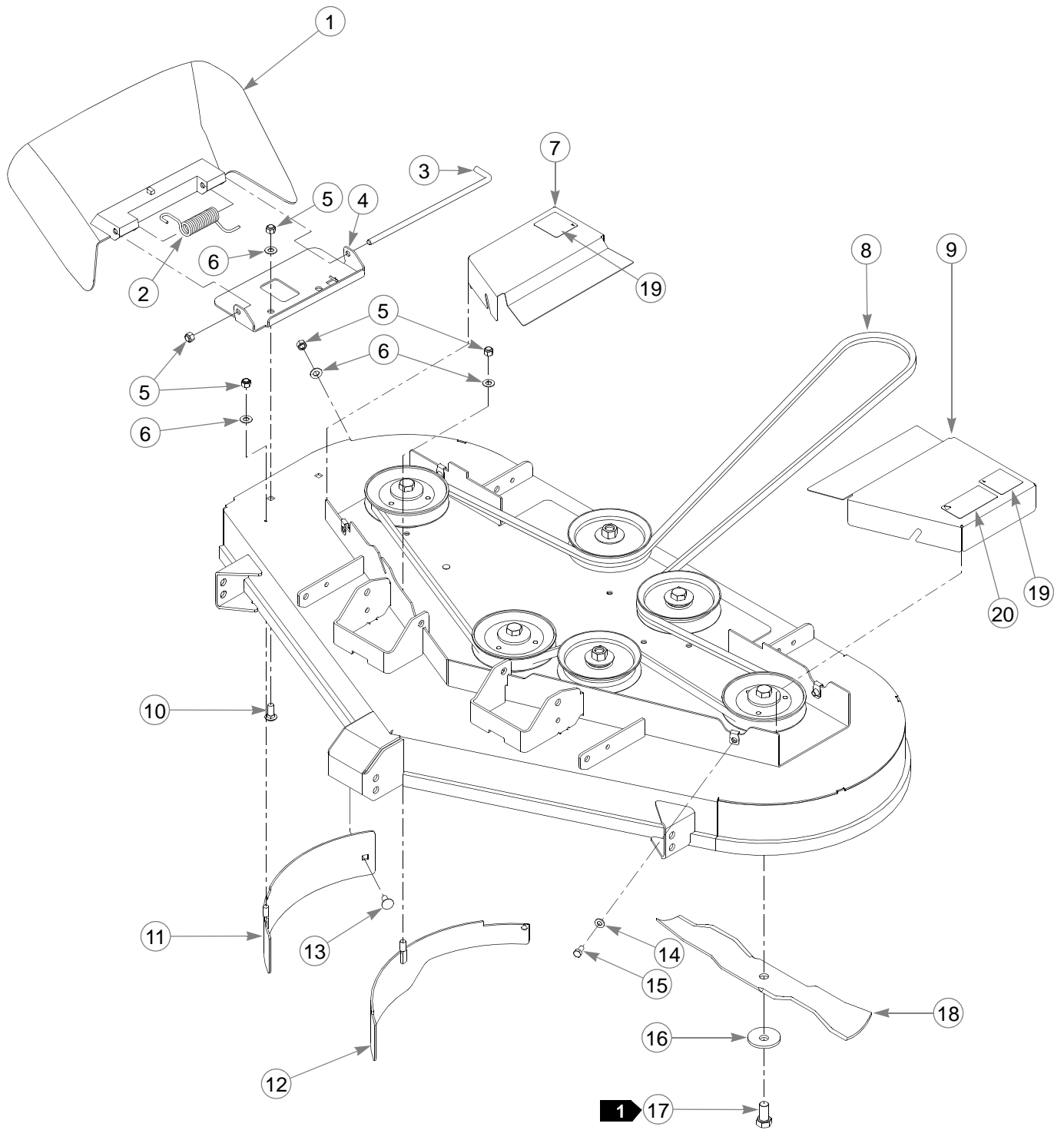

---

## **54" Deck**

INDEX NO.	PART NO.	QTY.	DESCRIPTION
1	601806	1	DISCHARGE CHUTE
2	602591	1	TORSION SPRING
3	601843	1	CHUTE PIN
4	112448	1	CHUTE BRACKET
5	086660	7	NT .375-16 HX G5 ZN NY
6	767954	6	FW .406 X .812 X .060 SAE
7	550489	1	PULLEY COVER, RS 54"
8	789388	1	BELT, B 152" EL
9	550490	1	PULLEY COVER, LS 54"
10	025395	2	CB .375-16 X 1.000 STD ZN
11	108202	1	BAFFLE MULCH W/A 54"
12	108200	2	BAFFLE MULCH, COMMON 54"
13	011320	1	CB .375-16 X .750 STD ZN
14	768523	4	FW .343 X .687 X .051/.080 HD ZN/YL
15	064006	4	CS .312-18X .625 HX G5
16	782474	3	CW .631 X 2.250 X .187 PNT
17	781872	3	CS .625-11 X 1.250 HX G5 ZN
18	797704	3	BLADE, 18.50"-MUL-F-CW
19	602562	2	DECAL, NO SERVICE
20	799171	1	DECAL, 54" DECK ID
21	797696	3	BLADE, F18.50"-H-F-CW (NOT SHOWN)

---

### **NOTES:**

1. Torque to 160 N.m..
2. Index 7 (550489) includes and index 19 ( No Service Decal) as a service part.
3. Index 11 (550490) includes index 20 (Deck ID Decal) and index 19 ( No Service Decal) as a service part.

---

## **54" Deck Belt Routing and Tensioning**

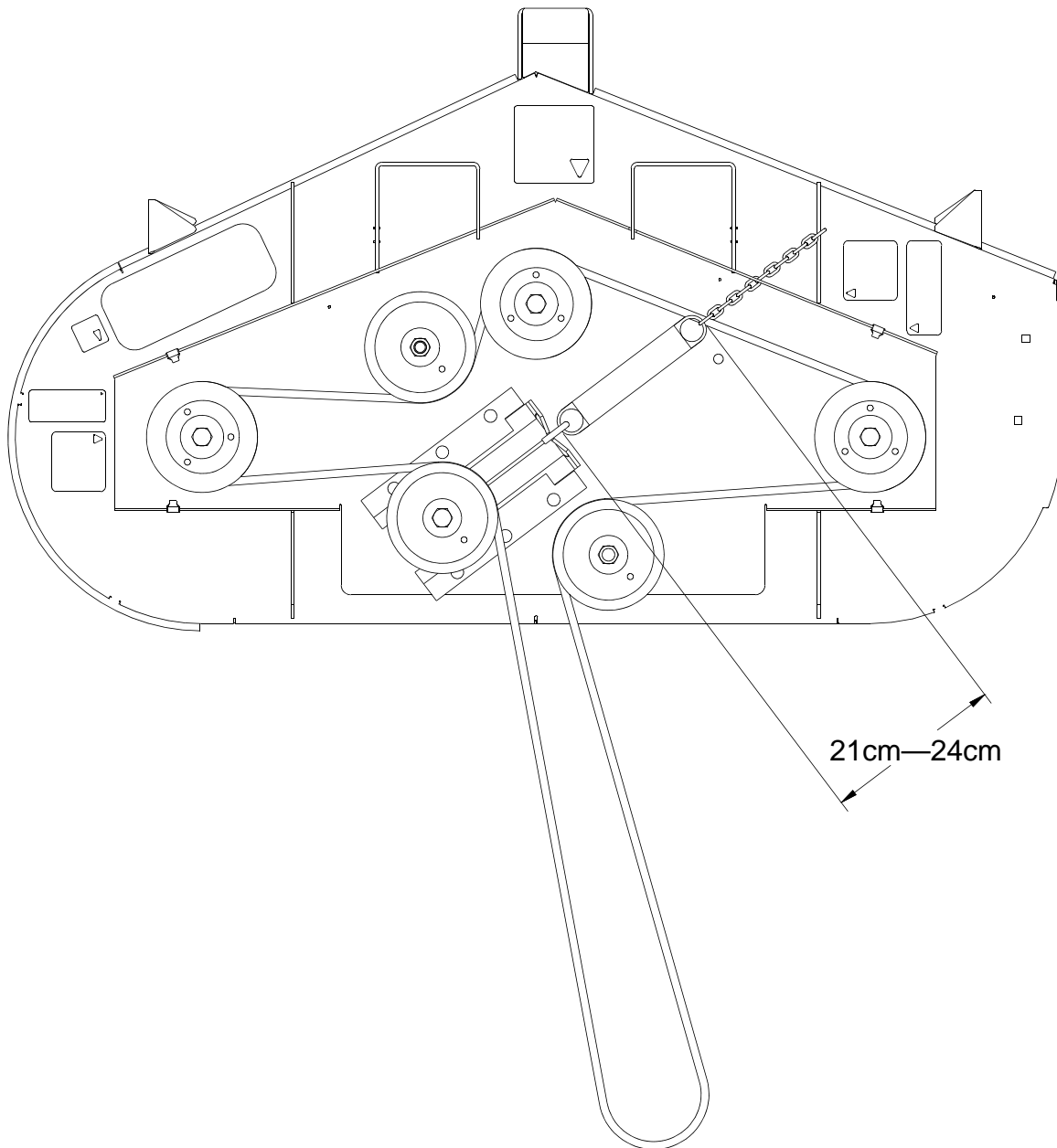

---

### **NOTES:**

4. Spring length after tensioning new belt. Measured from outside of hook to outside of hook at deck leveling height.
5. Route belt as shown.

---

**This page intentionally left blank.**

# Deck Lift

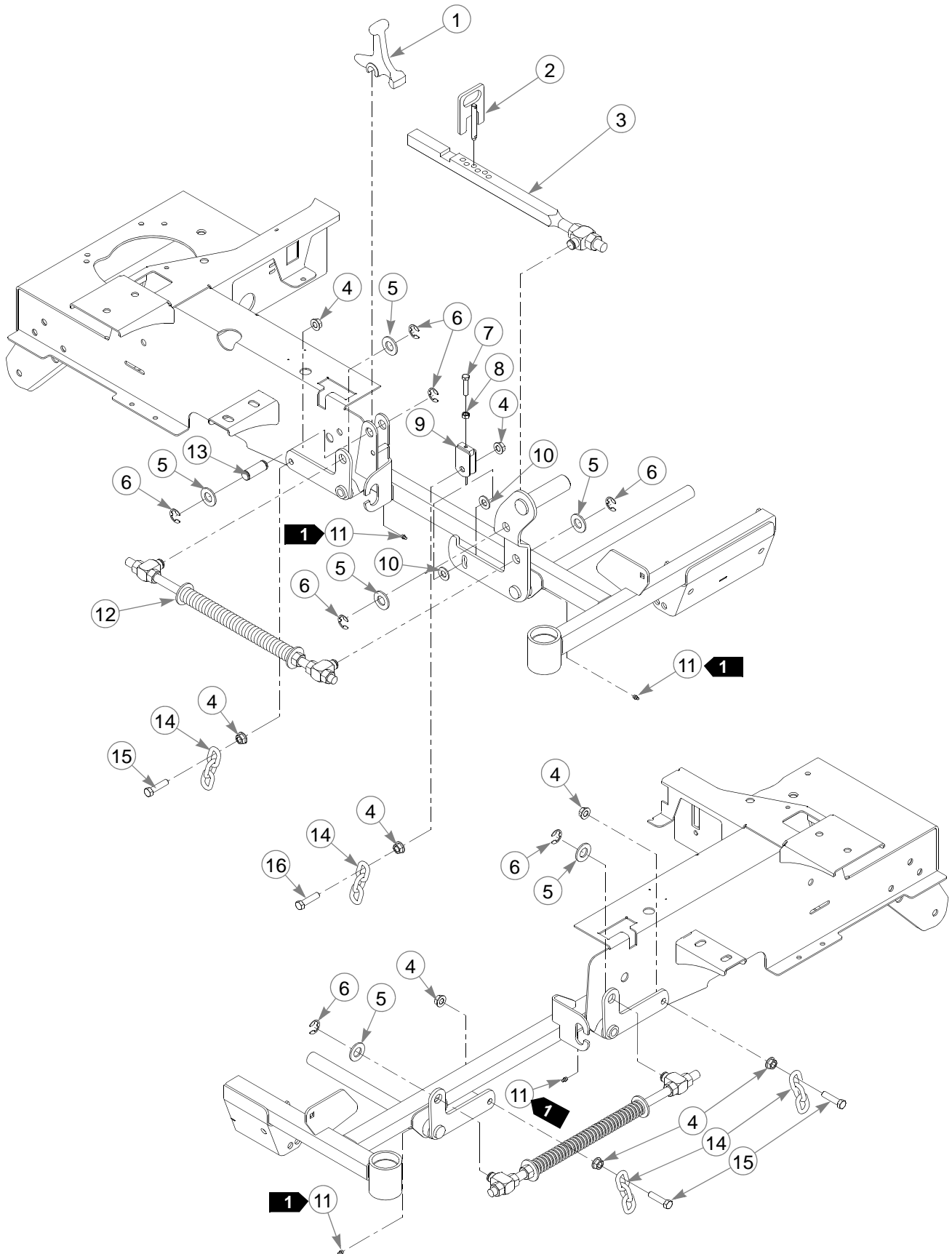



---

## **Deck Lift**

INDEX NO.	PART NO.	QTY.	DESCRIPTION
1	348318	1	STOP HANDLE
2	348284	1	HEIGHT ADJUSTMENT STOP
3	784488	1	DECK LIFT INDICATOR
4	704643	16	NT .437-14 HX FLG ZN
5	601681	6	FW .781 X1.50 X.120 ZNYC
6	781294	7	CLIP E, 1.00 X .625 X .050
7	756270	1	CS .312-18 X 1.50 FLTHR G
8	034272	1	NT .312-18 HX G5 ZNYC
9	348458	1	DECK LEVELER YOKE W/A
10	767962	6	FW .531 X 1.063 X .090 SAE
11	015495	4	STRAIGHT GREASE FITTING
12	782995	2	DECK LIFT SPRING
13	781229	1	CE .750 X 2.25 X 1.75 HEADLESS
14	360131	4	DECK LIFT CHAIN (3 LINKS)
15	055749	7	CS .437-14 X 1.750 HX G5 ZNYC
16	781831	1	CS .437-14 X 1.750 FULTH

---

### **NOTES:**

1. Apply grease to zerks.

# Deck Mounting Hardware

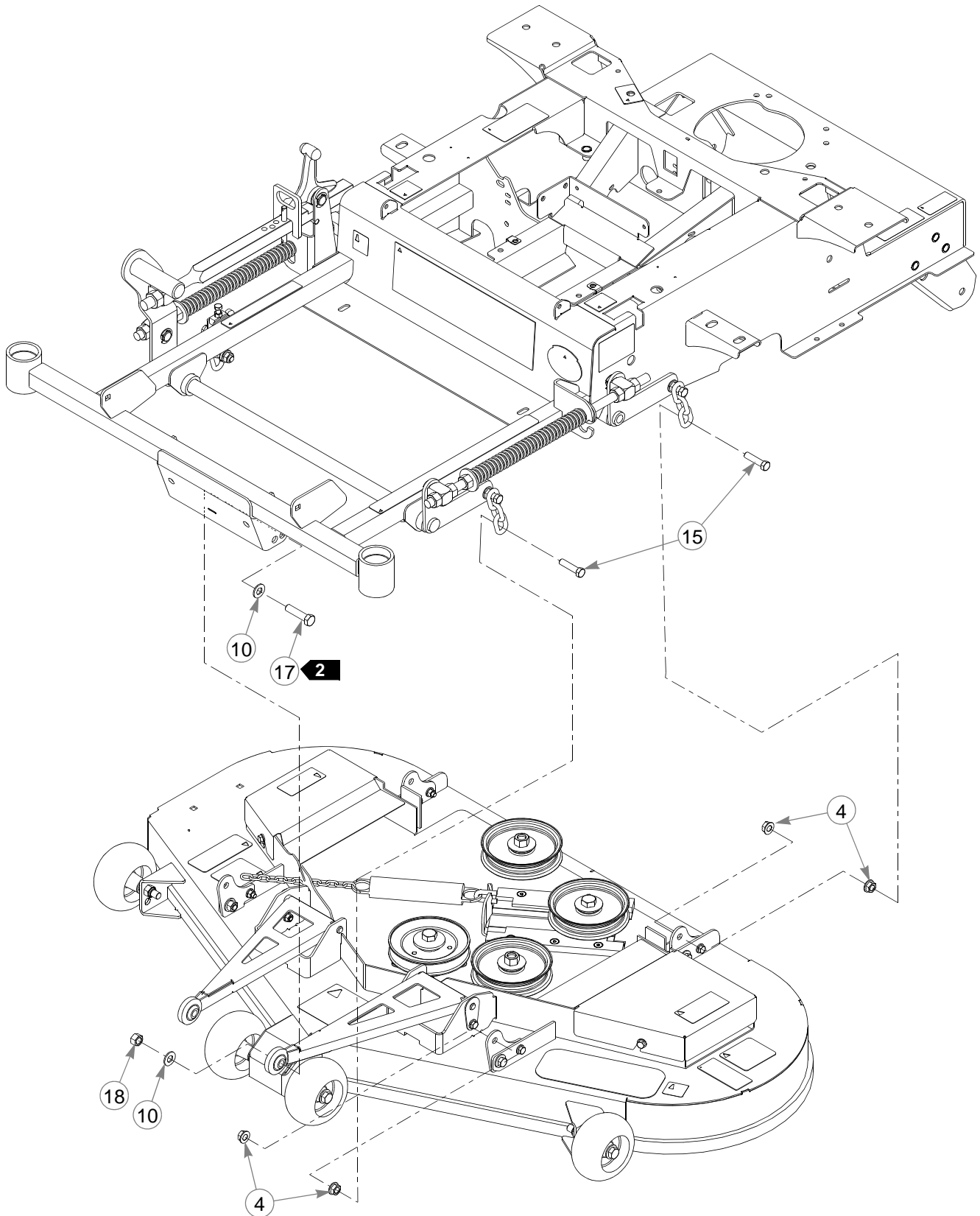

# Deck Mounting Hardware

INDEX NO.	PART NO.	QTY.	DESCRIPTION
17	078949	2	CS .500-13X 2.00 GR ZN
18	008193	2	NT .500-13 HX G5 ZN

## NOTES:

2. Install in rear hole of frame bracket.

## DECK BELT ADJUSTMENT

The spindle belt tension remains constant by means of a tension idler and spring. The spring tension should be such that the belt does not slip under normal operating load conditions, assuming the belt is not excessively worn or damaged. As the belt stretches and wears in, adjustment may become necessary. To increase belt tension, move the spring chain one (or more) link(s) at the anchor point on the deck frame.

**IMPORTANT:** Do not over tension the spring to compensate for a badly worn belt or pulley.

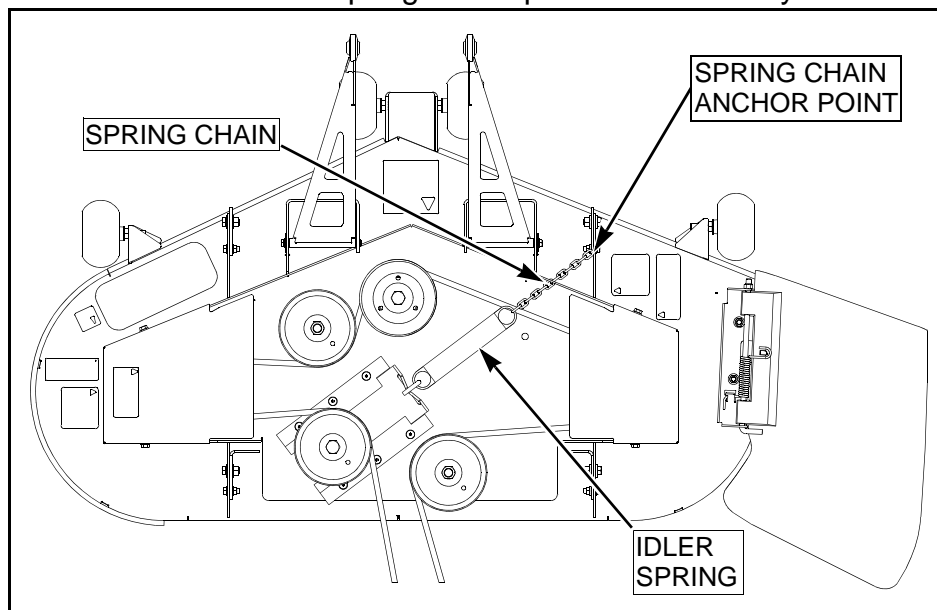

FIG. 1

## DECK LEVELING PROCEDURE

1. Check tire pressures (8–12 psi) to make certain they are properly inflated before starting to level deck.  
**NOTE: Stop engine. Make sure deck clutch switch is in the down (OFF) position. Remove ignition key. Place control levers in the brake position.**
2. Place 3" high deck support blocks (two stacked 2"x4" blocks can be used to create a 3" high support) at the four corners of the deck as indicated in FIG. 2.
3. Factory cutting height is set at 3¼" by placing the height stop in the 3" hole, with the flat side of height adjusting stop against the stop handle.
4. Secure the height stop against the stop handle with a clamp.
5. Loosen all nuts on the deck lift threaded rods (FIG. 4), and the hardware holding on the height indicator bar (on the right front) (FIG. 3), until ALL the deck lift chains are loose, AND the deck

is sitting tightly on all four blocks.

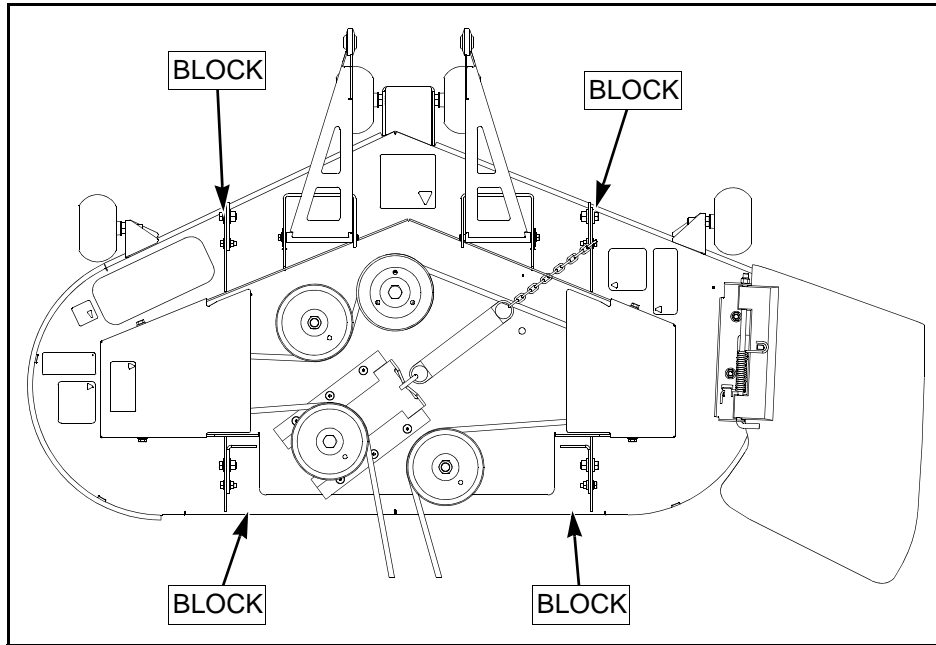

FIG. 2

6. Loosen the two nuts on the front of height indicator so that the foot pedal is free, FIG. 3.

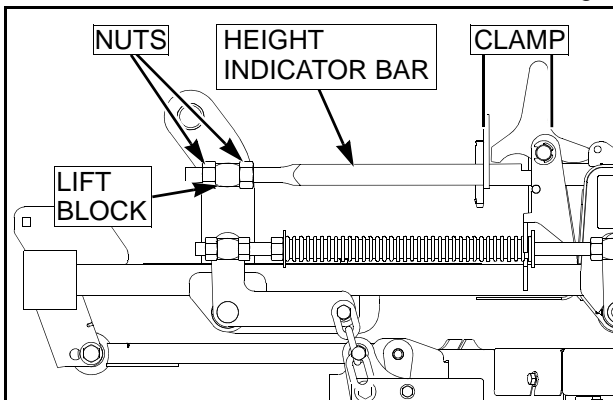

FIG. 3

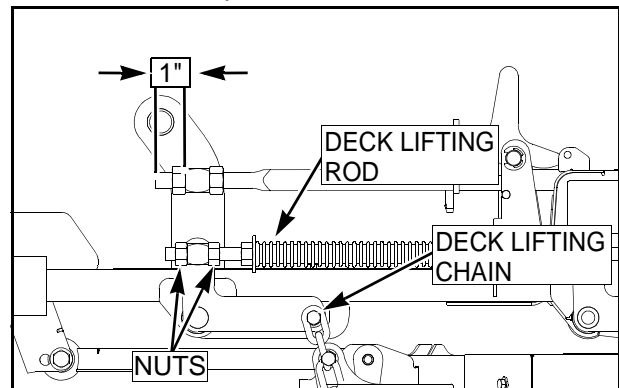

FIG. 4

7. Set the amount of threads protruding on the deck lift rod from the lift block at approximately 1" (FIG. 4).
8. Jam both nuts against the block.
9. Start the leveling process on the LEFT FRONT of the mower.
10. Push or pull on the deck lift pedal until the chain on the LEFT FRONT just becomes tight, making sure that the deck stays tight against the deck installation blocks (FIG. 2)
11. While keeping the chain tight, tighten the nuts against the deck lift block on the height indicator (FIG. 3).
12. Jam nuts tightly together against the deck lift block.
13. Go to the RIGHT FRONT of the mower.
14. Loosen the 7/16" flange nuts that clamp the adjuster to the deck lift arm (FIG. 5).
15. Loosen the 5/16" jam nut on the adjuster bolt, and back the adjuster bolt out to allow the

adjuster to move up and down freely. (FIG. 5).

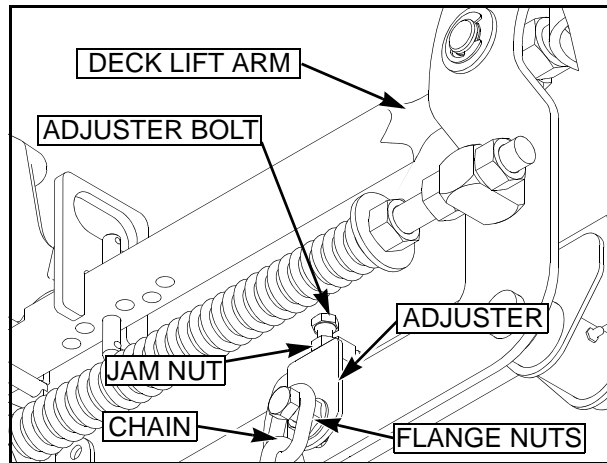

FIG. 5

16. Tighten the adjuster bolt until the chain just becomes tight, making sure that the deck stays tight against the blocks.
17. Tighten the adjuster bolt jam nut to prevent the adjuster from moving.
18. Tighten the 7/16" hardware holding the chain and adjuster onto the deck lift arm.
19. Go to the RIGHT REAR of the mower.
20. Make sure that there is still slack in the chain. If not, loosen the two nuts on the block holding the threaded rod until there is slack in the deck lift chain (FIG. 6).

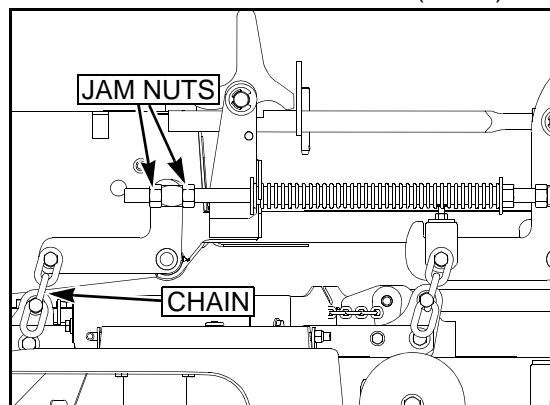

FIG. 6

21. Tighten the appropriate nut until the chain just becomes tight, making sure that the deck stays tight against the blocks (FIG. 6).
22. Tighten the other nut on the opposite side of the block, and jam them tightly together against the block.
23. Repeat step 21 for the LEFT REAR of the mower.
24. Compress the deck lift assist spring so that there is 1/2" of space between the front nut on the spring, and the rear nut on the deck lift block. (FIG. 7).

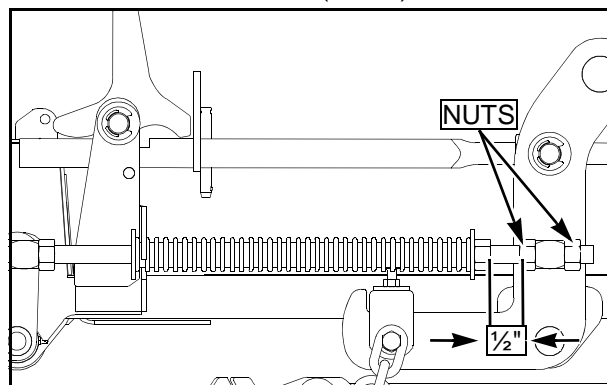

FIG. 7

25. When completed, all chains should be tight, and deck should still be resting on the four blocks.



---

## Section 8

Seat .....	8-2
ROPS.....	8-4

# Seat

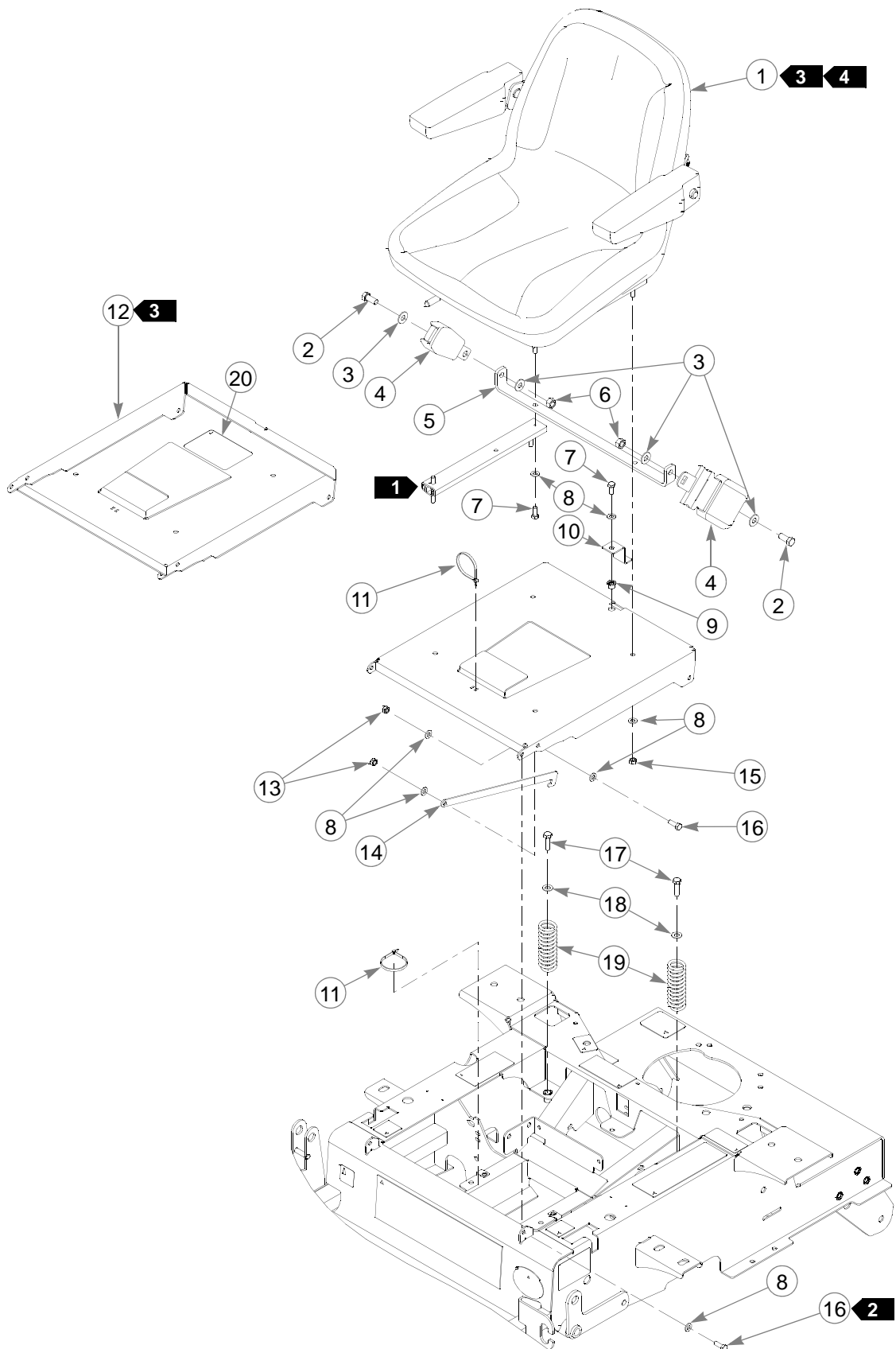



---

# Seat

INDEX NO.	PART NO.	QTY.	DESCRIPTION
1	793661	1	SEAT, MICHIGAN STANDARD
2	797076	2	CS .437-20 X1.00 HX G8 ZNYC
3	017129	4	FW .440 X 1.000 X.083 ZNY
4	601444	1	SEAT BELT
5	794610	1	BAR, SEAT BELT CROSS
6	704635	2	NT .437-20 HX GR5 ZNYC
7	034280	3	CS .312-18X .750 HX G5
8	768523	13	FW .343X.687X.051/.080H
9	808485	1	RIVET NUT, 5/16-18 THREAD
10	108321	1	SEAT LATCH
11	000331	2	WIRE TIE, SMALL/SHORT
12	550368	1	SEAT PAN
13	058776	3	NT .312-18 HXZY NL
14	109240	1	SEAT PAN STOP
15	034272	4	NT .312-18 HX G5 ZNYC
16	064014	3	CS .312-18X .875 HX G5
17	052860	2	CS .375-16X1.250 HX G5
18	767954	2	FW .406X .812 X.060 SAE
19	601450	2	SEAT SPRING
20	601815	1	BATTERY DECAL

---

## NOTES:

1. Part of 793661 (Standard Seat).
2. Do not torque item 16, the Seat Pan must pivot freely.
3. Item 12 includes, items 20 (727016) Battery Decal and item 21 (785147) Service Decal.
4. Service parts available for Michigan standard seat:

<u>PART NO.</u>	<u>DESCRIPTION</u>
793307	SLIDE KIT
793315	SEAT SWITCH
797464	ARMREST ASSY LH RND
797472	ARMREST ASSY RH RND
797480	ARMREST W/O BRACKET
793273	ARMREST STOP ASSEMBLY

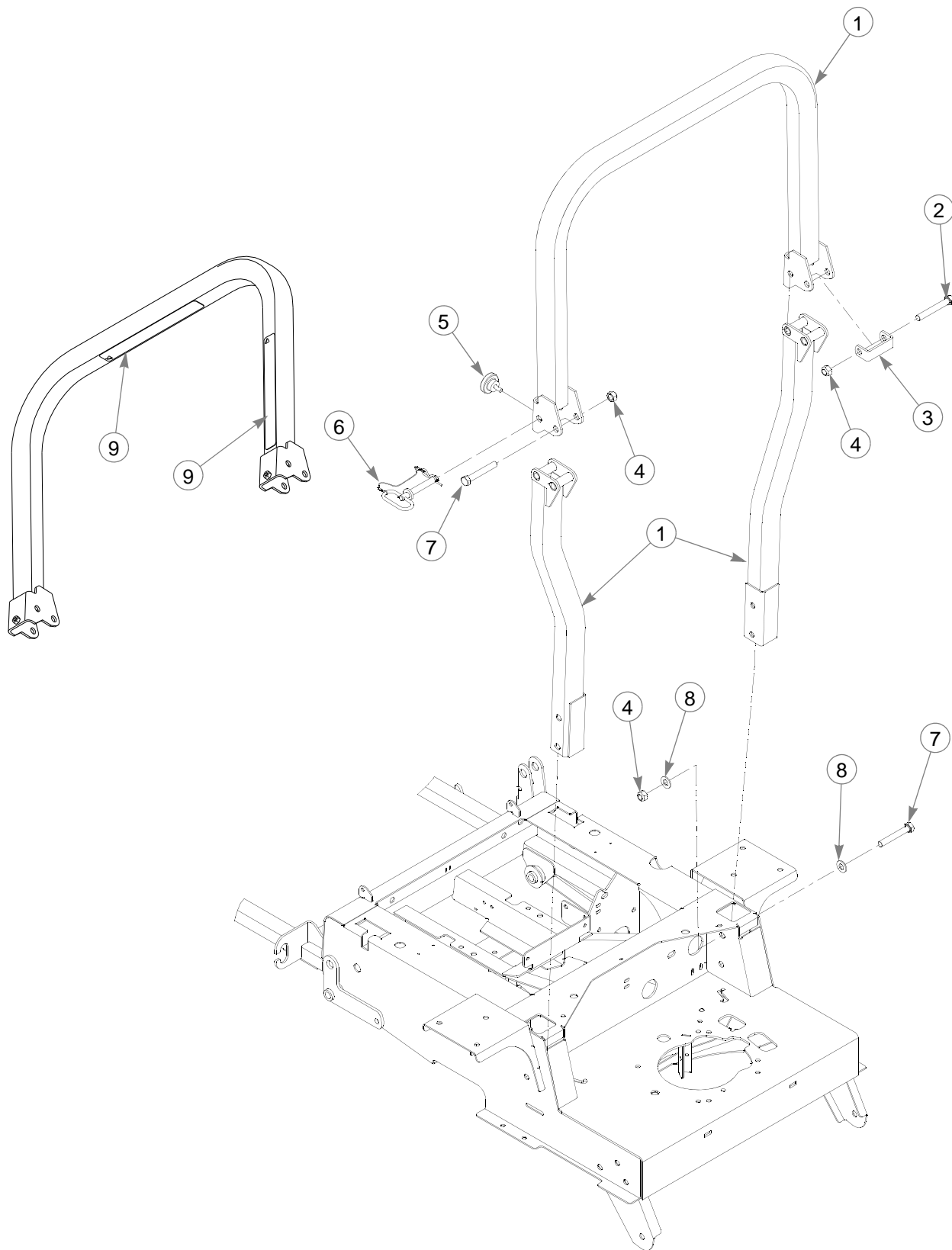

---

# **ROPS**

<b>INDEX NO.</b>	<b>PART NO.</b>	<b>QTY</b>	<b>DESCRIPTION</b>
1	602585	1	ROPS ASSEMBLY
2	061812	1	CS .500-13 X 3.500 HX GR5 ZN
3	601472	1	ROPS STOP
4	023317	6	NT .500-13 UNT LK G8 ZN
5	601470	2	KNOB, HAND FOR ROPS
6	601471	2	LYNCH PIN W/ LANYARD
7	077859	5	CS .500-13X 3.250 HX G5 ZN
8	767962	8	FW .531 X 1.063 X .09 SAE HRD ZN
9	601635	2	DECAL, ROP'S

---

## **NOTES:**



# Numerical Index

Part No.	Page No.	Part No.	Page No.	Part No.	Page No.
<b>Index</b>					
<b>Part Numbers</b>					
000323	5-3, 5-7	058776	5-3, 7-5, 8-3	550454	6-5
000331	3-3, 5-3, 5-7, 6-5, 8-3	059832	6-5	550489	7-9
000398	5-7	061077	4-3	550490	7-9
005108	3-13	061101	4-3	600221	3-5
005116	3-5, 7-5	061812	8-5	600296	7-5
008193	7-15	064006	7-9	600668	4-3
011320	2-5, 7-9	064014	8-3	600684	4-4
015495	7-13	068478	1-1	600759	3-3
015818	5-3, 5-7	068551	3-3, 3-5	600767	3-3
016253	5-3	077859	8-5	600880	3-3
016410	3-3	078949	7-15	600899	2-3
016816	3-13	080655	3-13	600972	3-3
016972	7-5	086660	2-5, 3-13, 7-9	600974	3-3
017004	5-3	102707	6-5	600975	3-3
017129	8-3	104786	5-3	600976	1-1, 3-3
019521	4-4	107881	3-3	600979	1-1, 3-3
023317	8-5	107892	3-13	600981	3-5
023655	3-5, 3-13	107893	3-13	600987	3-3
024927	3-5, 5-3, 6-3	108200	7-9	600991	3-13
025007	3-3, 7-5	108202	7-9	600994	2-3
025296	3-3, 4-3	108288	5-3	601001	3-3
025395	2-5, 7-9	108321	8-3	601002	5-3
026237	6-5	108541	2-6	601004	5-3
028118	3-3, 7-5	108847	2-6	601018	3-3
029868	6-3	108968	3-5	601051	3-13
029876	3-5, 5-3	108969	5-3	601062	5-3
030817	5-3	109200	7-6	601069	2-3, 7-2
031997	2-6, 7-5	109202	3-13	601084	3-3
034272	3-3, 3-5, 5-3, 5-7, 7-5, 7-6, 7-13, 8-3	109203	3-13	601087	3-13
034280	5-7, 7-5, 8-3	109238	7-6	601088	3-3
036236	3-5, 7-6	109239	7-6	601089	6-5
036384	3-3	109240	8-3	601094	6-5
038828	3-3	109247	7-5	601095	6-5
041152	3-5	109248	7-5	601098	6-5
041707	7-6	109318	3-5	601099	2-3
043570	5-3	109338	5-3	601131	3-13
044255	5-3	111875	4-3	601221	3-3
045898	6-5	112448	7-9	601312	5-3
046821	7-5	259812	7-5	601319	5-3
047746	7-6	344267	2-6, 4-3	601320	5-7
048553	3-3	348284	7-13	601321	5-7
050161	5-3	348318	7-13	601326	5-3
052860	2-6, 8-3	348417	6-3	601341	6-5
053199	7-5	348458	7-13	601348	4-4
054502	2-5, 2-6, 3-13, 7-5	348458	7-13	601349	4-3
055749	7-13	350884	7-5	601403	3-3
055822	5-7	360131	7-13	601404	3-3
055939	3-3, 3-5, 3-13, 5-3	361295	3-5	601410	3-13
055939	6-3	366625	4-3	601421	2-3
055947	6-5	548743CE	2-3	601429	5-3
		548768	2-5	601433	3-3
		550233	7-2	601434	7-5
		550368	8-3		

Part No.	Page No.	Part No.	Page No.	Part No.	Page No.
601444	8-3	767962	2-6, 7-5, 7-13, 8-5	785261	1-1
601450	8-3	768515	3-3, 3-5, 5-3, 6-5	785279	1-1
601452	5-3	768523	3-3, 3-5, 3-13, 5-3,	785378	5-3
601470	8-5		5-7, 6-3, 7-5, 7-6,	785485	2-5
601471	8-5		7-9, 8-3	785493	2-5
601472	8-5	769166	6-5	785634	1-1
601624	7-2	770867	2-6	785659	5-3
601635	8-5	771428	6-3	785808	6-5
601681	7-13	772079	1-1	786731	4-3
601806	7-9	776310	2-3	786848	3-3
601815	8-3	776476	6-5	786889	7-5
601837	7-2	778423	1-1	788166	2-6, 7-5
601843	7-9	779306	5-7	789388	1-1, 7-9
601941	3-3	780841	5-3	789776ce	2-3
601967	2-3	781153	3-3	791251	5-3
601981	2-3	781229	7-13	791335	1-1
602041	2-3	781260	3-10	791848	2-3
602233	6-5	781294	7-13	793273	8-3
602562	2-3, 7-9	781302	7-5	793307	8-3
602585	8-5	781567	7-5	793315	8-3
602591	7-9	781708	2-6, 7-5	793661	8-3
602882	1-1	781831	7-13	794446	3-3
602883	1-1	781856	7-5	794610	8-3
704163	3-5	781872	7-5, 7-9	794644	6-3
704635	8-3	781922	3-5	794685	1-1
704643	7-13	782292	1-1	795757	1-1
704932	6-5	782474	7-5, 7-9	796219	5-3
705954	4-3	782573	2-3	796524	5-3
706168	3-5	782664	5-3	797076	8-3
710087	3-3	782995	7-13	797449	7-5
712257	6-5	783506	7-5	797464	8-3
712372	5-3	783738	7-5	797472	8-3
712919	5-7	783761	5-3	797480	8-3
712976	4-3	784066	4-4	797696	1-1, 7-9
714618	6-3	784223	4-3	797704	7-9
727172	2-3, 7-2	784439	3-5	797910	7-5
728147	7-6	784488	7-13	799171	7-9
745059	5-7	784603	4-3	799411CE	1-1
756270	7-13	784918	5-3	808485	2-3, 8-3
763417	5-3	785055	7-2	808493	2-3
765339	3-13	785139	2-3	928382CE	1-1
767954	2-5, 2-6, 3-3, 3-13, 7-5, 7-9, 8-3	785154CE	2-3		
		785220	2-3		